



## INSTALLATION AND TUNING GUIDE

### CAN AM AO-P1 PDRIVE CLUTCH KIT

**PART NUMBER(s): AO-P1**

**WE ARE NOT RESPONSIBLE FOR ANY DAMAGES.  
BE VERY CAREFUL TO NOT DAMAGE YOUR CLUTCH  
DURING THIS PROCESS.**

#### TOOLS NEEDED

- 1/2" Drive Impact Gun
- 22mm or 7/8" - Wrench
- 17mm - 1/2" Drive Socket
- Torque Wrench
- 6mm Allen Wrench
- T30 Torx
- T25 Torx
- KWI MAVTOOL V2 clutch tool set or equivalent
- Clutch Belt removal tool
- Blue Locktite
- Long 3/8" or 1/4" drive extension



#### ESTIMATED INSTALL TIME

40 MINUTES

#### Removing and Installing the KWI AO-P1 weights

- 1) Remove CVT belt. (Clutch Belt removal tool)
- 2) Remove 3 cam arm pin retaining screws. (T25 Torx)
- 3) Remove cam arm pins. (KWI "The Hammer" Pin Removal Tool and "THE TIP" 5mm extractor or equivalent)
- 4) Remove the cam arms. You may need to push in on the outer sheave a bit to allow the arms to be slid out.  
**(preferred method is to use the primary opening tool included in our KWI V2 tool kit)**
- 5) Properly configure the magnet, clicker position and pivot bolt setup on the AO-P1 cam arms for your vehicle using the setup chart.
- 6) Install the AO-P1 cam arms in your clutch and secure with the pin and pin retaining screw, torque to specs in torque chart on page 4. You may need to push in on the outer sheave a bit to allow the arms to be slid in.  
**(preferred method is to use the primary opening tool included in our KWI V2 tool kit)**

# INITIAL SETUP CHART MAGNET ADJUSTMENT

**ADJUST THE MAGNETS to get your RPM set properly BEFORE ADJUSTING THE PIVOT BOLTS OR CLICKERS! This requires the cam arms be removed from the clutch.**

The weight of the added magnets affects RPM. The more magnets that are installed the lower the RPMS will be. If you remove magnets the RPM will increase.



- 1) Remove or add magnets as required. If there are 2 holes in the AO-P1 cam arms to place magnets- you can place magnets in either hole but magnets MUST be distributed so that the clutch is balanced so make sure arms with identical magnets are either placed across from each other or in every other position to maintain clutch balance. Do not overfill magnet slots (FLUSH IS FULL)!
- 2) Reinstall the KWI AO-P1 cam arms in your clutch and secure with the pin and pin retaining screw. You may need to push in on the outer sheave a bit to allow the arms to be slid in. **(preferred method is to use the primary opening tool included in our KWI V2 tool kit)**

CAN AM HD11 TURBO AOP-1 SETUP CHART								
For High Altitudes- subtract 15% from the Published HP range of your tune to get actual effective HP. Example - 200 CHP (at sea level) x .85 = 170CHP (use the 175CHP line in the chart below as your baseline setting)								
For sand dunes or large tires (35"+)- subtract 8% from the Published HP range of your tune to get actual effective HP. Example - 200 CHP x .92 = 184CHP (use the 175CHP line in the chart below as your baseline setting)								
For tires 28" and smaller- Add 8% from the Published HP range of your tune to get actual effective HP. Example - 200 CHP x .1.08 = 216CHP (use the 215CHP line in the chart below as your baseline setting)								
For Launch Control - Install the HIGH ENGAGEMENT primary spring (Sold Separately) as it is a high engagement spring and will raise engagement RPMS. Add 2 thick magnets or install a longer pivot bolt (if the magnet slots are full) to the suggested settings in the chart below compensate shift RPM for additional HIGH ENGAGEMENT spring pressure.								
Crankshaft horsepower (CHP) /Wheel horsepower (WHP)	# of Magnets per cam arm	Pivot bolt	Clicker setting	Primary spring	Secondary spring / Helix / hole	Belt Recommendation	Full throttle RPM at 55mph	
120CHP/100WHP	HP TOO LOW - CANNOT USE AOP-1 CLUTCH KIT- MUST USE DEFCOM 7 CLUTCH KIT							
152CHP/130WHP								
175CHP/165WHP	0 in mid 0 in tip	25mm	Position #3 (Factory Setting)	OEM	KWI DR3 GROOVIX- OEM TURBO RR Black/Green OR Dark Blu/Pink secondary spring in hole #2 (35 degrees wrap)	Gates 48R4289 Gboost WBB652RS OR WBB383	7850 RPM +/- 100 RPM (ALL TURBOS)	
195CHP/175WHP	0 in mid 1 in tip	25mm						
215CHP/185WHP	1 in mid 2 in tip	30mm						
225CHP/195WHP	1 in mid 4 in tip	35mm						
255CHP/225WHP	3 in mid 4 in tip	35mm						

CAN AM X3 AOP-1 SETUP CHART								
The chart below is a guideline with very close start points with 30-33" tires riding at Sea Level elevation. (choose the Crankshaft horsepower/Wheel horsepower that best matches your X3) (Identical cars may have HP differences of up to 10 HP due to engine manufacturing tolerances so clutch kit calibration adjustments are necessary in most cases)								
For High Altitudes- subtract 15% from the Published HP range of your tune to get actual effective HP. Example - 200 CHP (at sea level) x .85 = 170CHP (use the 175CHP line in the chart below as your baseline setting)								
For sand dunes or large tires (35"+)- subtract 8% from the Published HP range of your tune to get actual effective HP. Example - 200 CHP x .92 = 184CHP (use the 175CHP line in the chart below as your baseline setting)								
For tires 28" and smaller- Add 8% from the Published HP range of your tune to get actual effective HP. Example - 200 CHP x .1.08 = 216CHP (use the 215CHP line in the chart below as your baseline setting)								
For Launch Control - Install the HIGH ENGAGEMENT primary spring (Sold Separately) as it is a high engagement spring and will raise engagement RPMS. Add 2 thick magnets or install a longer pivot bolt (if the magnet slots are full) to the suggested settings in the chart below compensate shift RPM for additional HIGH ENGAGEMENT spring pressure.								
Crankshaft horsepower (CHP) /Wheel horsepower (WHP)	# of Magnets per cam arm	Pivot bolt	Clicker setting	Primary spring	Secondary spring / Helix / hole	Belt Recommendation	Full throttle RPM at 55mph	
120CHP/100WHP	HP TOO LOW - CANNOT USE AOP-1 CLUTCH KIT- MUST USE DEFCOM 7 CLUTCH KIT							
152CHP/130WHP								
175CHP/165WHP	0 in mid 4 in tip	30mm	Position #3 (Factory Setting)	OEM	OEM TURBO RR HELIX- OEM TURBO RR Black/Green secondary spring in hole #4 (30 degrees wrap) KWI DR3 GROOVIX- OEM TURBO RR Black/Green secondary spring in hole #2 (35 degrees wrap)	Gates 48R4289 Gboost WBB652RS OR WBB383	7850 RPM +/- 100 RPM (ALL OEM TURBOS)	
195CHP/175WHP	2 in mid 4 in tip	25mm						
215CHP/185WHP	2 in mid 4 in tip	30mm						
225CHP/195WHP	2 in mid 4 in tip	35mm						
255CHP/225WHP	4 in mid 4 in tip	35mm						
265CHP/230WHP	2 in mid 4 in tip	35mm						
290CHP/250WHP	4 in mid 4 in tip	35mm						
330CHP/275WHP	2 in mid 4 in tip	35mm						
360CHP/310WHP	2 in mid 4 in tip	35mm						
KWI GROOVIX DR3 HELIX- KWI DARK BLUE/PINK SPRING IN HOLE #4 (15 degrees wrap)								

**PDRIVE PRIMARY NOT RECOMMENDED ABOVE 370CHP/320WP.**

## TROUBLESHOOTING

**BEFORE YOU MAKE ANY CLUTCHING ADJUSTMENTS OR CONTACT KWI FOR SUPPORT VERIFY THE FOLLOWING!!!**

\*\*\* Clutching only reacts to the available HP or drivetrain loads, most often low power is the cause of poor clutching performance and the issue is not the clutching itself. The AO calibrations have been verified to produce correct RPM on thousands of vehicles so if you install per your published HP on the chart and the RPM is not correct you must suspect poor engine performance as the issue first.

\*\*\* #1 CAUSE OF LOW RPM IS POOR ENGINE PERFORMANCE - troubleshoot for power loss, incorrect wastegate actuator crack pressure, boost leaks, poor fuel or that your not using the "normal key" which limits power to 60% before making additional clutching adjustments. This is the first thing we will ask you when you call us so make sure you've verified these are correct. (Refer to the KWI videos under the support section on our website or YouTube for additional help)

## CLICKER CAM RPM ADJUSTMENT

This can be done easily from outside the clutch without removing the belt.

-To adjust, modify ramp end position by turning ramp cams ( IMPORTANT TO DO THIS ON ALL 3 ARMS).

-The ramp and the right lever have a notch while ramp cam has 5 positions numbered 1 to 5. Each number modifies maximum engine RPM by about 150 RPM.

-Lower numbers decrease engine RPM in steps of 150 RPM and higher numbers increase it in steps of 150 RPM.

-For example: Ramp cam is set at position #3 and is changed to position #5 so maximum engine RPM is to be increased by about 300 RPM

1. Loosen the pivot bolt.
2. Move right lever aside to be able to turn the cam.
3. Turn cam to the desired position. You may need to push in on the outer sheave a bit to allow the cam to turn easily. **(Always adjust all 3 cams and make sure they are all set at the same number)**
4. Put BLUE Locktite on pivot bolt then tighten to specifications in torque chart on page 4.

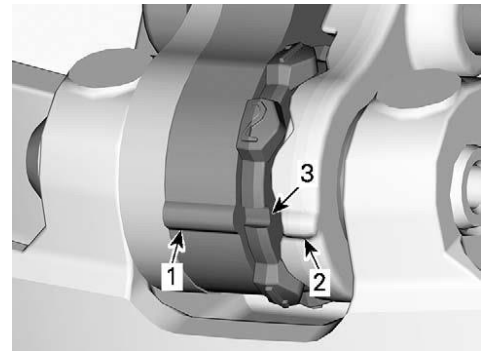

1. Ramp notch
2. Right lever
3. Cam position (here #3 - factory setting, no number)

## PIVOT BOLT RPM ADJUSTMENT

This can be done easily from outside the clutch. The weight of the pivot bolt affects RPM slightly and most noticeably just above engagement RPM. The heavier (longer) the pivot bolt the lower the RPMS will be.

1. Remove the pivot bolt.
2. Install the desired pivot bolt with BLUE Locktite and tighten to specifications in torque chart on page 4.

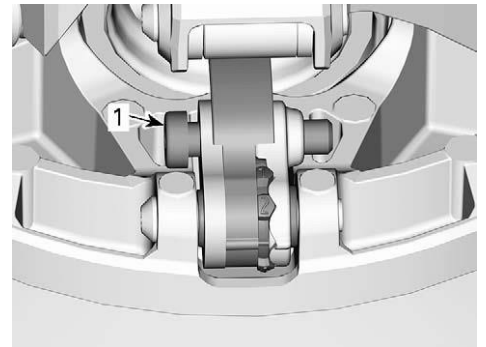

1. Pivot Bolt

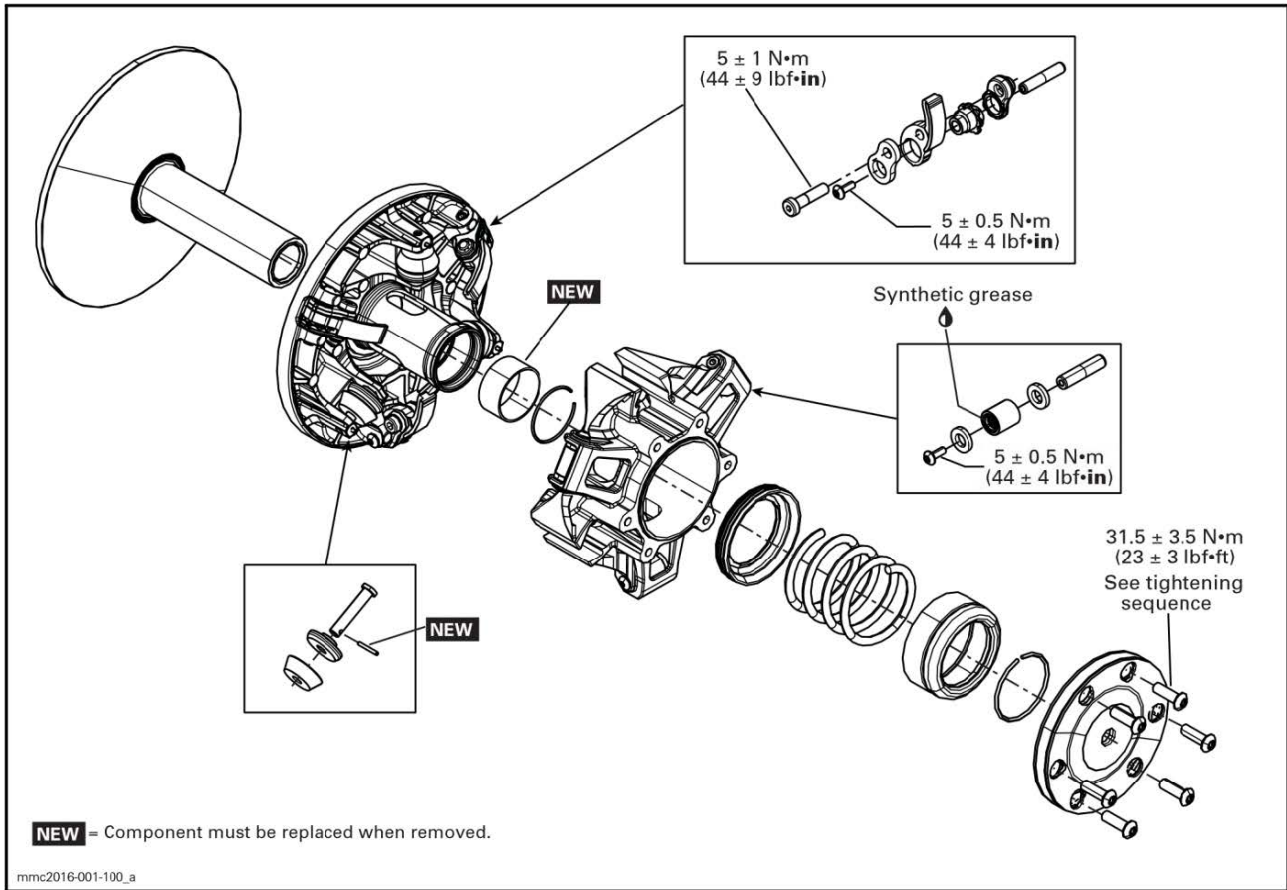

### KWI PDRIVE X PARTS INCLUDED

PART DESCRIPTION	QTY	OEM PART #	OUR PART #
AO-P1 PDRIVE ADJUSTABLE CAM ARM	3	—	AOP-1
25MM PIVOT BOLT	3	—	—
30MM PIVOT BOLT	3	—	—
35MM PIVOT BOLT	3	—	—
MAGNET PACK	1	—	—
		—	—
		—	—

#### LIABILITY STATEMENT

As defined by the Magnuson-Moss warranty Act. Do not install any performance parts or services unless you have the technical ability to properly set-up the entire machine to compensate for the installation of those parts. The necessary work and expertise needed to install different product varies. Instructions, where provided, are given to assist in installation only; they are not a substitute for mechanical experience in setting up racing vehicles. References to performance gains, reliability, ease of installation, etc. are based on our and outside customer's experiences. This is not a guarantee of similar performance in every installation. While we sell proven products, in the end it's up to the individual to make the most of the product. Kris Werth Inc. d.b.a. KWI Clutching or its associated corporations are not responsible for any personal or property damages caused by this product. Kris Werth Inc. d.b.a. KWI Clutching or its associated corporations assumes no responsibility for damage or injury of any kind because of misuse, improper installation or improper application of any parts in anyway, by any person. Contact your local dealer to schedule installation of this kit if you are not a qualified ATV or UTV mechanic. USE OF PRODUCTS. BUYER SHALL USE, AND REQUIRE ITS EMPLOYEES, CONTRACTORS, AND AGENTS TO USE, ALL AVAILABLE SAFETY PRECAUTIONS, IN ADDITION TO ANY SPECIFICALLY SET FORTH IN ANY MANUALS, MATERIAL SAFETY DATA SHEETS, TECHNICAL DATA SHEETS, INSTRUCTION SHEETS, IF ANY, FURNISHED BY SELLER (OR AVAILABLE FROM RAW MATERIAL SUPPLIERS) RELATING TO SELLER'S PRODUCTS. IF BUYER DOES NOT RECEIVE ANY REQUIRED MATERIAL SAFETY DATA SHEETS FOR ANY PRODUCT FROM SELLER, BUYER WILL REQUEST THEM FROM SELLER. IF BUYER FAILS TO STRICTLY OBSERVE EACH AND EVERY ONE OF THE OBLIGATIONS SET FORTH IN THIS SECTION 22 OR IF BUYER'S USE OF ANY OF SELLER'S PRODUCTS IS IN VIOLATION OF ANY STANDARD OR RULE OF THE AMERICAN NATIONAL STANDARDS INSTITUTE OR OCCUPATIONAL HEALTH AND SAFETY ACT, OR OTHER APPLICABLE WORKPLACE LAW, REGULATION, OR STANDARD, BUYER WILL INDEMNIFY, DEFEND, AND HOLD HARMLESS SELLER AND SELLER AND ITS EMPLOYEES, OFFICERS, DIRECTORS, AGENTS, AFFILIATES, SUCCESSORS AND ASSIGNS FROM AND AGAINST ANY AND ALL CLAIMS, DEMANDS, DAMAGES, ACTIONS, AND CAUSES OF ACTION, AS WELL AS ANY AND ALL LIABILITY, LOSS, OR EXPENSE OF ANY KIND, INCLUDING REASONABLE ATTORNEYS' FEES ARISING FROM, CONNECTED WITH OR IN ANY WAY PERTAINING TO ANY SUCH FAILURE BY BUYER. NOTIFICATION. BUYER SHALL NOTIFY SELLER PROMPTLY, AND IN ANY EVENT WITHIN 30 DAYS, AFTER ANY ACCIDENT OR FAILURE INVOLVING SELLER'S PRODUCTS THAT RESULTS IN PERSONAL INJURY OR DAMAGE TO PROPERTY AND SHALL COOPERATE FULLY WITH SELLER IN INVESTIGATING AND DETERMINING CAUSES OF SUCH ACCIDENT OR FAILURE. ATTORNEYS' FEES AND COSTS. BUYER WILL PAY SELLER'S REASONABLE ATTORNEYS' FEES AND OTHER COSTS AND EXPENSES FOR ANY LEGAL OR EQUITABLE ACTION UNDERTAKEN BY SELLER TO ENFORCE THESE TERMS OR THE PROVISIONS OF ANY SUPPLY AGREEMENT.