

# Converter System/Clutch

## Table of Contents

Exploded View .....	6-2
Specifications .....	6-6
Special Tools and Sealants .....	6-7
Torque Converter Cover .....	6-9
Torque Converter Cover Removal .....	6-9
Torque Converter Cover Installation .....	6-9
Drive Belt .....	6-10
Drive Belt Removal .....	6-10
Drive Belt Installation .....	6-10
Drive Belt Inspection .....	6-11
Drive Pulley .....	6-12
Drive Pulley Removal.....	6-12
Drive Pulley Installation.....	6-12
Drive Pulley Disassembly .....	6-13
Drive Pulley Inspection .....	6-13
Drive Pulley Assembly .....	6-14
Driven Pulley .....	6-15
Driven Pulley Removal.....	6-15
Driven Pulley Installation.....	6-15
Driven Pulley Disassembly .....	6-16
Driven Pulley Inspection .....	6-17
Driven Pulley Assembly .....	6-18
Torque Converter Housing.....	6-21
Torque Converter Housing Removal.....	6-21
Torque Converter Housing Installation.....	6-21
Clutch Cover Removal .....	6-23
Clutch Cover Installation.....	6-23
Clutch Cover Disassembly.....	6-24
Clutch Cover Assembly.....	6-25
Clutch .....	6-27
Clutch Removal.....	6-27
Clutch Installation.....	6-27
Clutch Shoe Lining Wear Inspection.....	6-27
One-Way Clutch Inspection .....	6-28
Converter Duct .....	6-29
CVT Pre Filter Removal .....	6-29
CVT Pre Filter Installation .....	6-29
CVT Pre Filter Inspection.....	6-29
CVT Pre Filter Housing Removal.....	6-29
CVT Pre Filter Housing Installation.....	6-29
Upper CVT Intake Duct Removal.....	6-30
Upper CVT Intake Duct Installation.....	6-30
CVT Exhaust Duct Removal .....	6-30
CVT Exhaust Duct Installation .....	6-30

# 6-2 CONVERTER SYSTEM/CLUTCH

## Exploded View

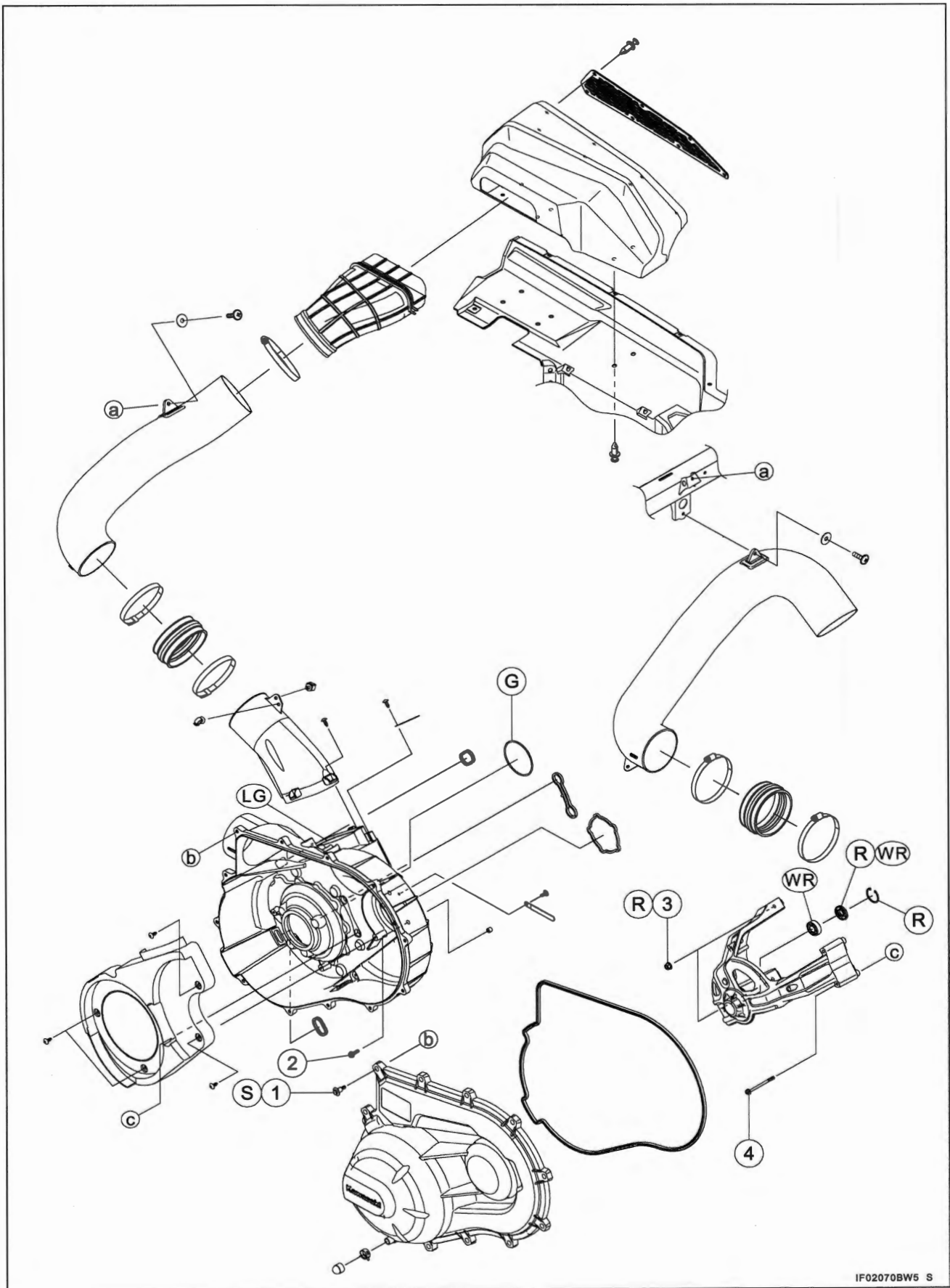

**Exploded View**

No.	Fastener	Torque			Remarks
		N·m	kgf·m	ft·lb	
1	Torque Converter Cover Bolts	9.0	0.92	80 in·lb	S
2	Torque Converter Housing Bolts	9.0	0.92	80 in·lb	
3	Drive Pulley Housing Nuts	20	2.0	15	R
4	Drive Pulley Housing Bolts	15	1.5	11	

G: Apply grease.

LG: Apply liquid gasket.

R: Replacement Parts

S: Follow the specified tightening sequence.

WR: Apply grease (WR500-No2. KYODO YUSHI, POWER LITE WR #2 KYODO YUSHI, or SERAN -HV TOTAL FINA).



**Exploded View**

No.	Fastener	Torque			Remarks
		N·m	kgf·m	ft·lb	
1	Clutch Cover Bolts	20	2.0	15	
2	Clutch Hub Bolts	127	13.0	93.7	MO, S
3	Clutch Cover Bearing Holder Bolts	15	1.5	11	L
4	Propeller Shaft Bearing Case Bolts	25	2.5	18	
5	Propeller Shaft Bearing Case Bracket Bolts	25	2.5	18	
6	Engine Side Plate Bolts	40	4.1	30	
7	Engine/Transmission Case Bracket Bolt (M8)	25	2.5	18	
8	Drive Pulley Nut	230	23.5	170	
9	Drive Pulley Cover Bolts	12.5	1.27	111 in·lb	
10	Driven Pulley Bolt	135	13.8	100	Lh

EO: Apply engine oil.

G: Apply grease.

L: Apply a non-permanent locking agent.

Lh: Left-hand Threads

MO: Apply molybdenum disulfide oil solution.

(mixture of the engine oil and molybdenum disulfide grease in a weight ratio 10:1)

R: Replacement Parts

S: Follow the specified tightening sequence.

WR: Apply grease (WR500-No2. KYODO YUSHI, POWER LITE WR #2 KYODO YUSHI, or SERAN -HV TOTAL FINA).

## 6-6 CONVERTER SYSTEM/CLUTCH

### Specifications

Item	Standard	Service Limit
<b>Drive Belt</b>		
Belt Width	37.7 ~ 38.9 mm (1.48 ~ 1.53 in.)	36.8 mm (1.45 in.)
<b>Drive Pulley</b>		
Weight Cam Thickness	— — —	3.7 mm (0.15 in.)
Shoe Side Clearance	Up to 0.15 mm (0.0059 in.)	1.0 mm (0.039 in.)
End Cover Bushing Inside Diameter	31.982 ~ 32.079 mm (1.2591 ~ 1.2630 in.)	32.38 mm (1.275 in.)
Spring Free Length	81.5 mm (3.21 in.)	— — —
<b>Driven Pulley</b>		
Sheave Bushing Inside Diameter	45.000 ~ 45.085 mm (1.7716 ~ 1.7750 in.)	45.3 mm (1.78 in.)
Spring Free Length	152.5 mm (6.00 in.)	— — —
<b>Clutch</b>		
Clutch Housing Inside Diameter	160.000 ~ 160.200 mm (6.2992 ~ 6.3071 in.)	160.25 mm (6.3090 in.)
Clutch Shoe Groove Depth	1.0 mm (0.039 in.)	0.5 mm (0.02 in.)

## Special Tools and Sealants

**Inside Circlip Pliers:**  
57001-143

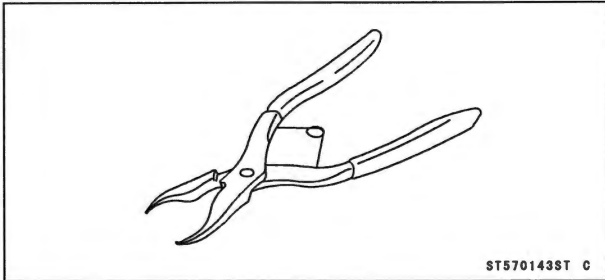

**Outside Circlip Pliers:**  
57001-144

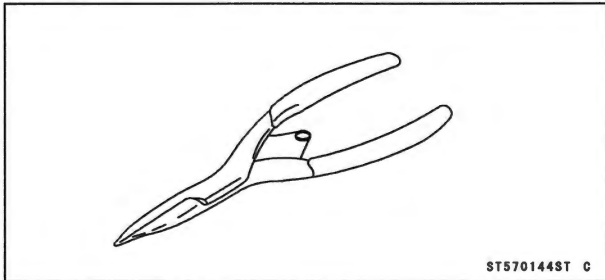

**Bearing Driver Set:**  
57001-1129

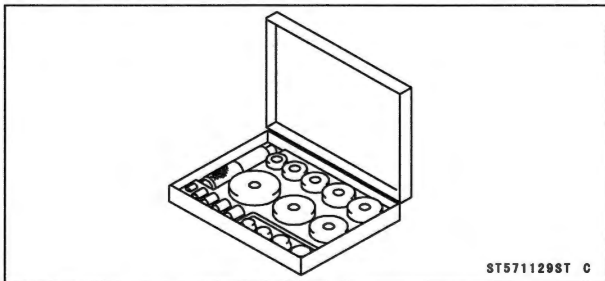

**Steering Stem Bearing Driver,  $\phi 42.5$ :**  
57001-1344

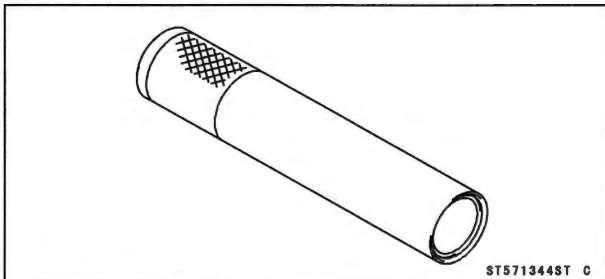

**Drive Pulley Holder:**  
57001-1620

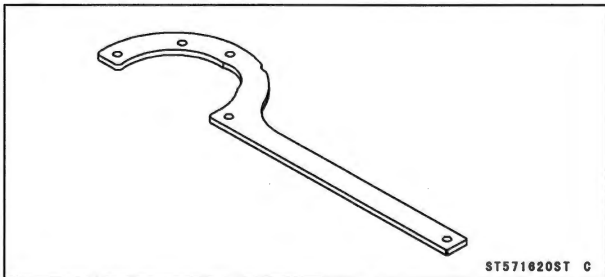

**Bearing Driver,  $\phi 76$ :**  
57001-1780

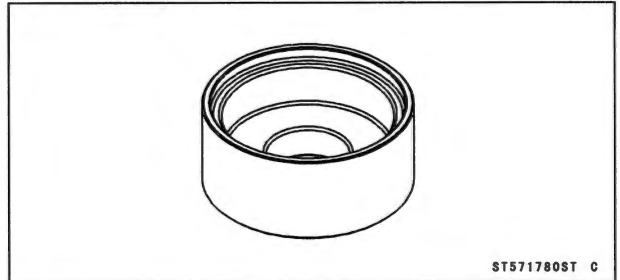

**Driven Pulley Holder:**  
57001-1918

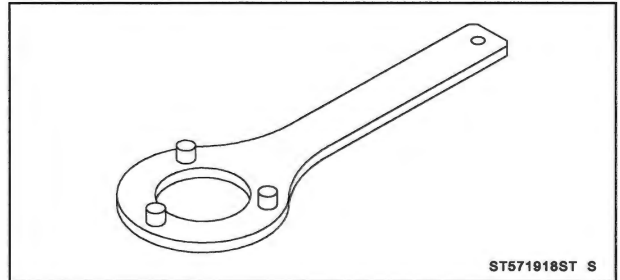

**Drive Pulley Puller:**  
57001-1919

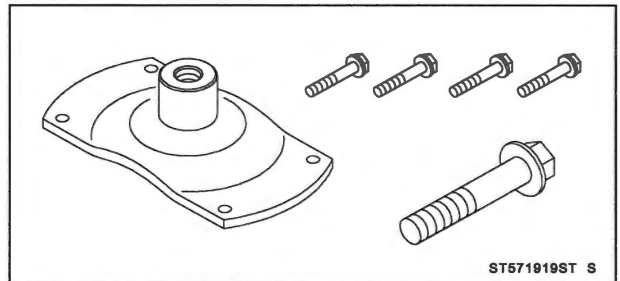

**Driven Pulley Puller:**  
57001-1920

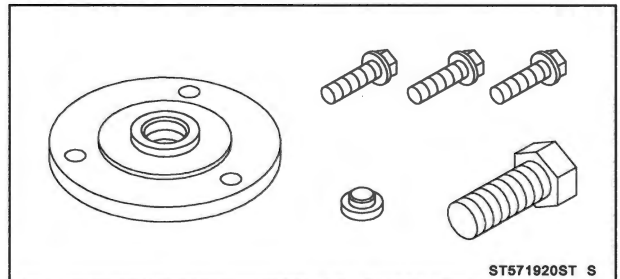

**Driven Pulley Spring Compressor:**  
57001-1921

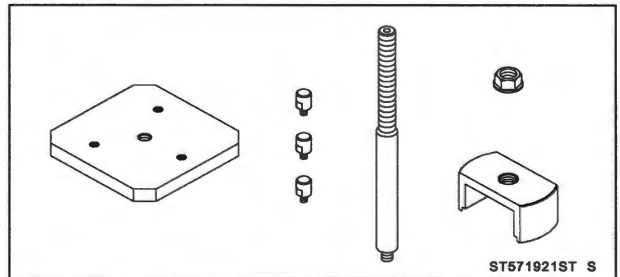

# 6-8 CONVERTER SYSTEM/CLUTCH

## Special Tools and Sealants

**Clutch Holder:**  
**57001-1922**

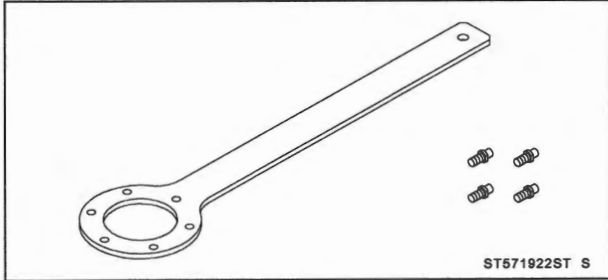

**Clutch Housing Remover:**  
**57001-1925**

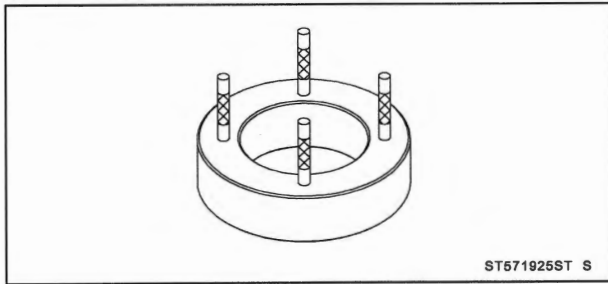

**Liquid Gasket, TB1211F:**  
**92104-0004**

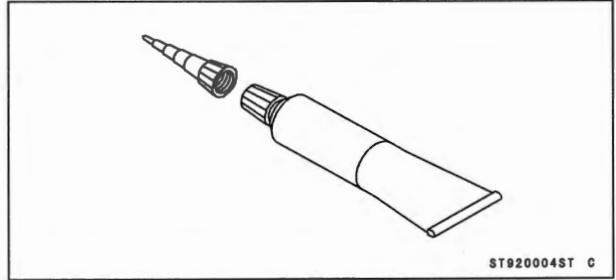

**Liquid Gasket, TB1216:**  
**92104-1063**

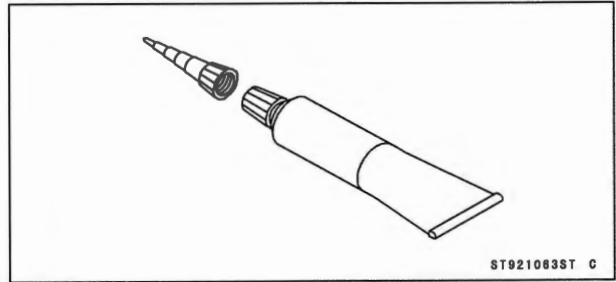

## Torque Converter Cover

### **⚠ WARNING**

Excessive imbalance or operating rpm could cause torque converter pulley failure resulting in severe injury or death. The pulleys of the belt drive torque converter are precision balanced components designed to operate within certain rpm limits. Disassembly/assembly and servicing procedures of the pulley assemblies must be followed closely. Modifications to the engine or pulleys that increase rpm may cause failure.

### **Torque Converter Cover Removal**

- Remove:
  - Left Rear Wheel (see Wheel Removal(11-8))
  - Left Rear Shock Absorber (see Rear Shock Absorber Removal(14-11))
  - CVT Cover Plate Bolt and Washers [A]
  - CVT Cover Plate [B]
  - Torque Converter Cover Bolts [C]
  - Torque Converter Cover [D]

- ★ If necessary, remove the following parts.
  - Clamp [A]
  - Drain Boot [B]

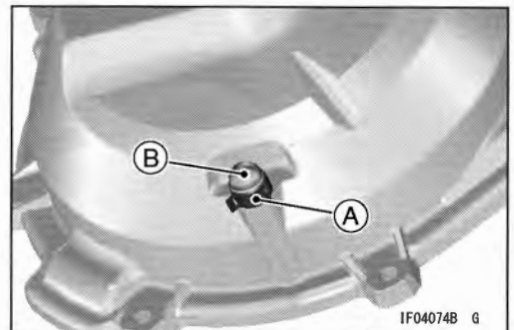
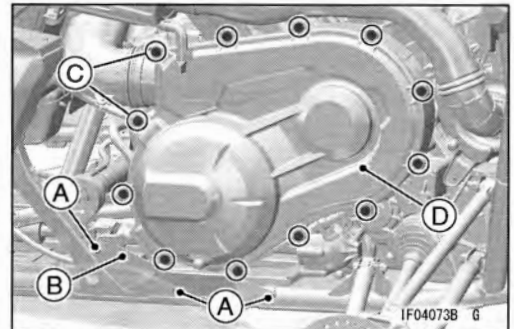

### **Torque Converter Cover Installation**

- ★ If necessary, install the following parts with new ones.
  - Clamp
  - Drain Boot
- ★ If necessary, replace the trim seal [A] with a new one.
- Fit the trim seal into the torque converter cover [B] as shown.

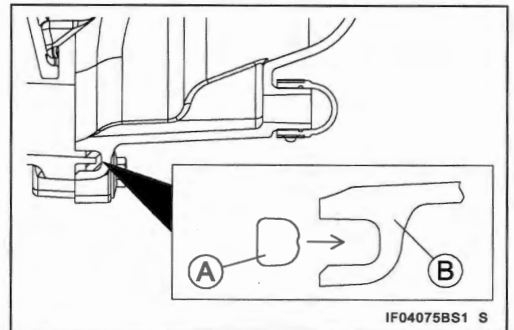

- Install:
  - Torque Converter Cover
- Tighten the converter cover bolts following tightening sequence [1 ~ 12].
  - Torque - Torque Converter Cover Bolts: 9.0 N·m (0.92 kgf·m, 80 in·lb)**
- Install the removed parts.

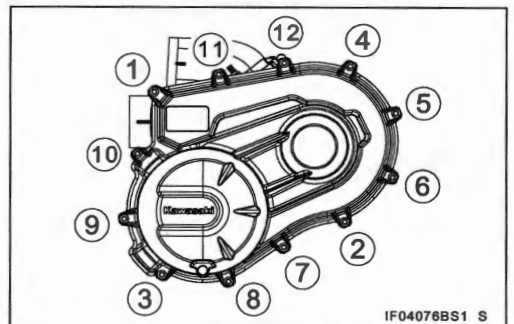

# 6-10 CONVERTER SYSTEM/CLUTCH

## Drive Belt

### Drive Belt Removal

- Remove:
  - Torque Converter Cover (see [Torque Converter Cover Removal\(6-9\)](#))
  - Drive Pulley Housing Bolts [A]
  - Drive Pulley Housing Nuts [B]
  - Drive Pulley Housing [C]

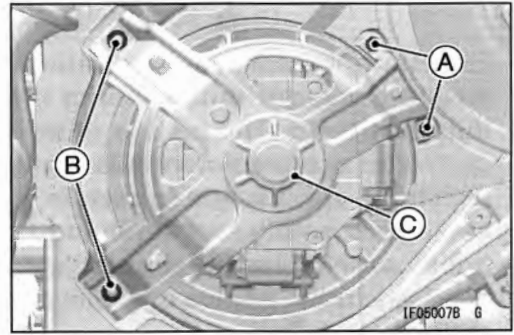

- Install the suitable bolts [A] to the driven pulley [B].  
Suitable Bolt: 130BA1060 or equivalent
- Tighten evenly the bolts.
- There will be a gap at the sheave of the driven pulley after tightening.

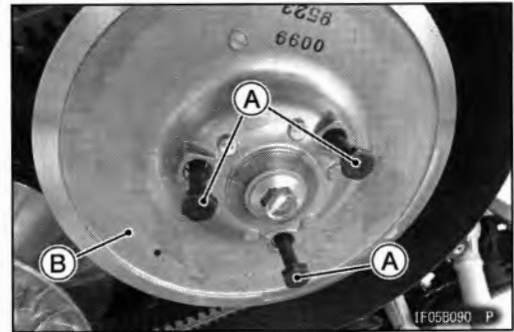

- Remove the drive belt [A].

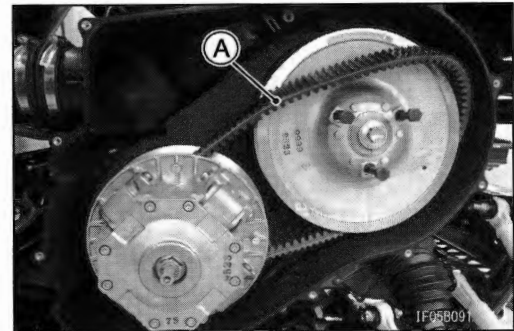

- ★ If necessary, remove the following parts.
  - Circlip [A]
  - Oil Seal [B]
  - Ball Bearing [C]

**Special Tool - Inside Circlip Pliers: 57001-143**

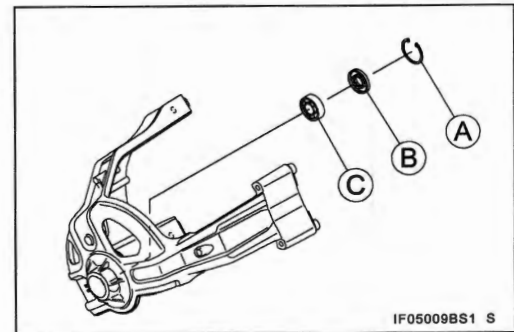

### Drive Belt Installation

- Install the suitable bolts [A] to the driven pulley [B].  
Suitable Bolt: 130BA1060 or equivalent
- Tighten evenly the bolts.
- There will be a gap at the sheave of the driven pulley after tightening.

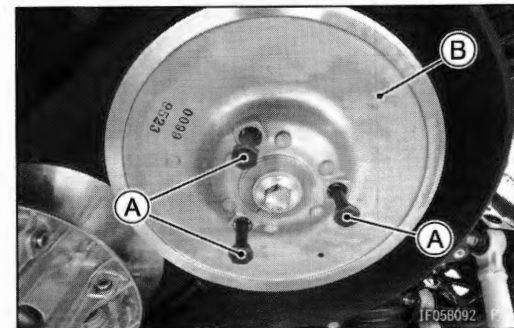

## Drive Belt

- Install the drive belt so that the printed arrow mark [A] is pointed toward as shown.
- Remove evenly the bolts [B] to close the sheaves.

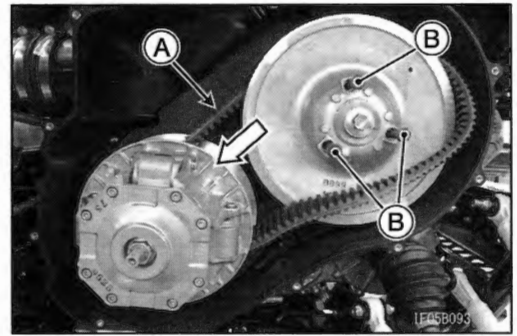

★ If necessary, replace the following parts with new ones.

Ball Bearing  
Oil Seal  
Circlip

- Apply grease (WR500-No.2 (KYODO YUSHI), POWER LITE WR #2 (KYODO YUSHI), or SERAN-HV (TOTAL FINA)) to the bearing inside diameter [A] and ball bearing [B].
- Press in the ball bearing until it is bottomed.

**Special Tool - Bearing Driver Set: 57001-1129**

- Apply grease to the oil seal lips.
- Press in the oil seal [C] in the torque converter cover as shown.  
3.5 mm (0.13 in.) [D] or less

**Special Tool - Bearing Driver Set: 57001-1129**

- Install the circlip [E].

**Special Tool - Inside Circlip Pliers: 57001-143**

- Replace the drive pulley housing nuts with new ones.
- Install the drive pulley housing [A].

**Torque - Drive Pulley Housing Bolts [B]: 15.0 N·m (1.5 kgf·m, 11 in·lb)**

**Drive Pulley Housing Nuts [C]: 20.0 N·m (2.0 kgf·m, 15 in·lb)**

- Install the removed parts.

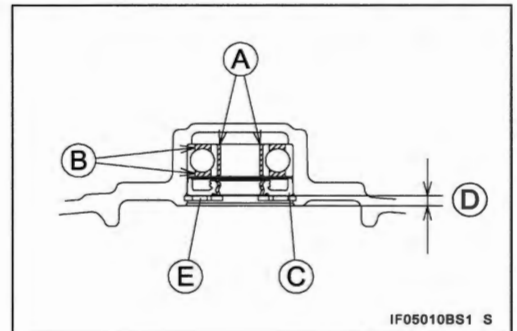

IF05010BS1 S

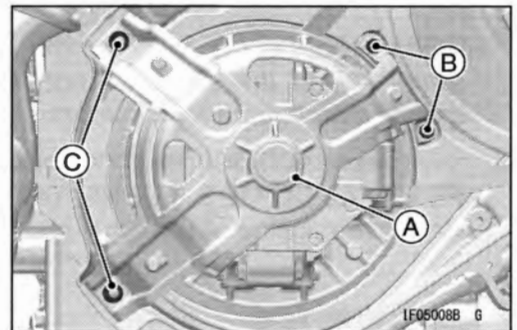

IF05008B G

### **Drive Belt Inspection**

- Refer to the Converter Drive Belt Wear Inspection (see Converter Drive Belt Wear Inspection(2-31)).

# 6-12 CONVERTER SYSTEM/CLUTCH

## Drive Pulley

### Drive Pulley Removal

- Remove:
  - Drive Belt (see Drive Belt Removal(6-10))
- Remove the three drive pulley cover bolts and install the drive pulley holder [A] with the suitable bolts [B].  
**Special Tool - Drive Pulley Holder: 57001-1620**  
Suitable Bolt: 130BA0635 or equivalent
- Tighten the suitable bolts.
- Loosen the drive pulley nut [C], holding the drive pulley with the drive pulley holder.
- Remove the drive pulley nut and washer.
- Remove:
  - Suitable Bolts
  - Drive Pulley Holder
  - Drive Pulley

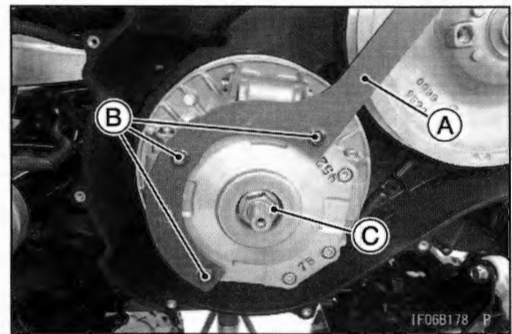

- ★ If the drive pulley [A] seems too difficult to remove, remove the four drive pulley cover bolts and use the drive pulley puller [B].

**Special Tool - Drive Pulley Puller: 57001-1919**

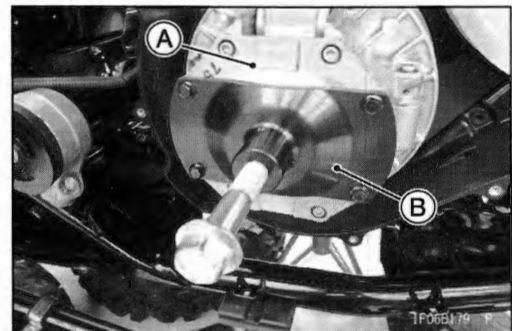

### Drive Pulley Installation

- Clean the drive shaft [A].

#### NOTE

○ When engaging the spline on the drive pulley with the spline [B] on the shaft, do not damage the pulley's spline. If any damage occurs, remove it with a file.

- Apply grease (WR500-No.2 (KYODO YUSHI), POWER LITE WR #2 (KYODO YUSHI), or SERAN-HV (TOTAL FINA)) to the spline of the drive shaft.
- Install:
  - Driven Pulley [A]
- Wipe off the excess grease [B].
- Install:
  - Washer [C]
  - Nut [D]

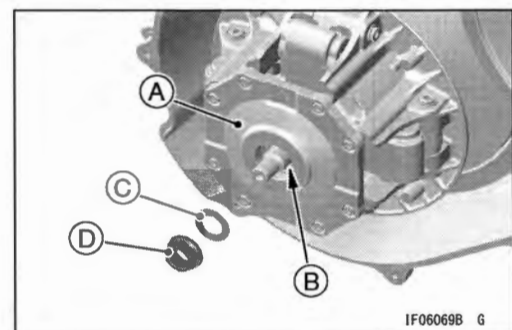
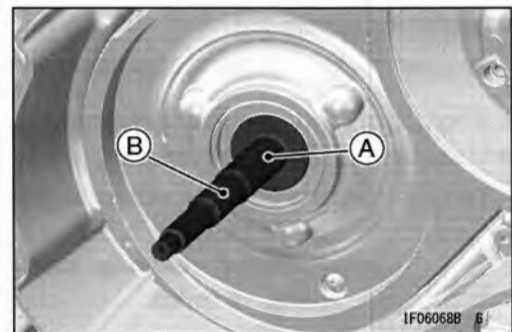

## Drive Pulley

- Remove the three drive pulley cover bolts and install the drive pulley holder [A] with the suitable bolts [B].

**Special Tool - Drive Pulley Holder: 57001-1620**

Suitable Bolt: 130BA0635 or equivalent

- Tighten the suitable bolts.
- Tighten the drive pulley nut [C].

**Torque - Drive Pulley Nut: 230 N·m (23.5 kgf·m, 170 ft·lb)**

- Remove:
  - Suitable Bolts
  - Drive Pulley Holder

- Tighten:
  - Torque - Drive Pulley Cover Bolts: 12.5 N·m (1.27 kgf·m, 111 in·lb)**

- Wipe the excess grease off the drive shaft.

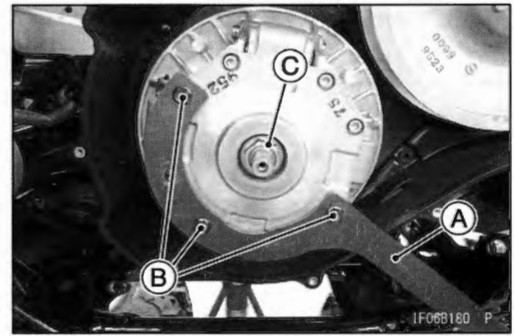

## Drive Pulley Disassembly

- Remove:
  - Drive Pulley (see Drive Pulley Removal(6-12))
  - Drive Pulley Cover Bolts [A]
  - Drive Pulley Cover [B]

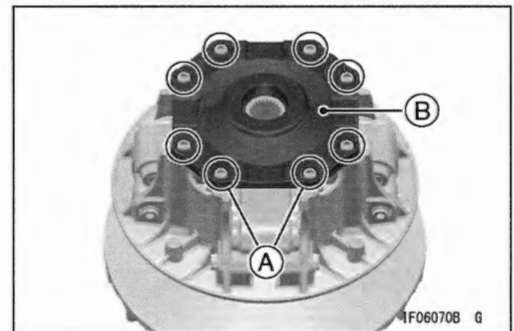

- Remove:
  - Spring [A]

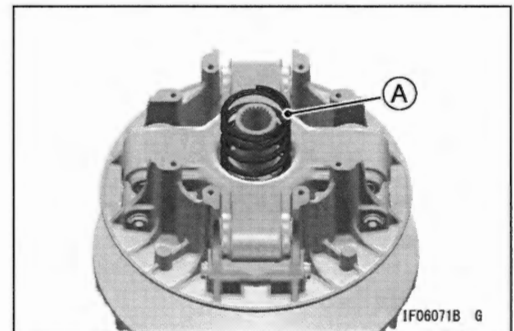

- Remove:
  - Circlip [A]
  - Ramp Weight Pin [B]
  - Ramp Weight [C]

**Special Tool - Outside Circlip Pliers: 57001-144**

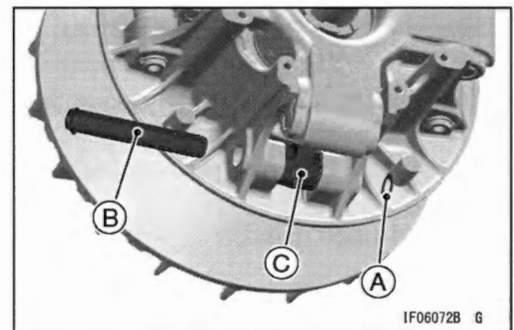

## Drive Pulley Inspection

- Refer to the Converter Drive Pulley Inspection (see Converter Drive Pulley Inspection(2-32)).

## 6-14 CONVERTER SYSTEM/CLUTCH

### Drive Pulley

#### Drive Pulley Assembly

- When installing the ramp weight bushing [A], press [B] the bushing into the ramp weight [C] from the mark [D] side so that the surface is flush [E] with the ends of the ramp weight.

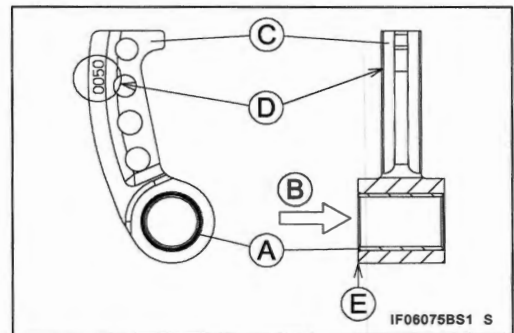

- Replace the circlip with a new one.
- Install:
  - Ramp Weight [A]
  - Ramp Weight Pin [B]
  - Circlip [C]
- **Special Tool - Outside Circlip Pliers: 57001-144**
- Check that the ramp weights swing smoothly.

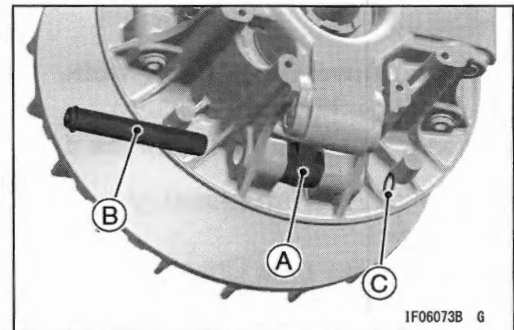

- Put the spring [A] in the groove of the spider.

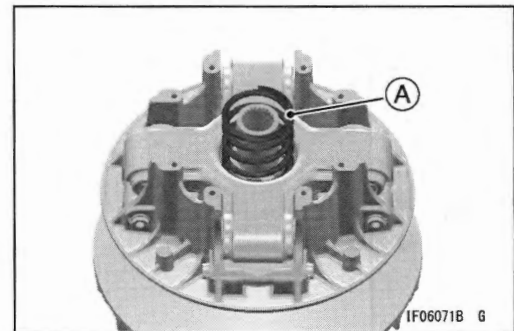

- Align the arrows [A] on the drive pulley cover and movable sheave.
- Install:
  - Drive Pulley Cover [B]
- Tighten:
  - Torque - Drive Pulley Cover Bolts: 12.5 N·m (1.27 kgf·m, 111 in·lb)**
- Clean the surface of the sheaves with an oil-less cleaning fluid.
- Check that the drive pulley assembly moves smoothly.
- Install:
  - Drive Pulley (see Drive Pulley Installation(6-12))

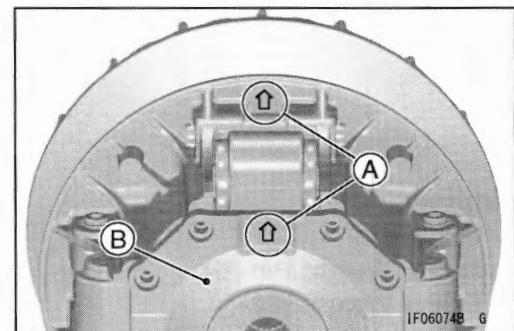

## Driven Pulley

### Driven Pulley Removal

- Remove:  
Drive Belt (see Drive Belt Removal(6-10))
- Using the driven pulley holder [A], remove the driven pulley bolt [B] and washer.

**Special Tool - Driven Pulley Holder: 57001-1918**

#### NOTE

○The driven pulley bolt has left-hand threads.

- Remove:  
Driven Pulley
- ★If the driven pulley [A] seems too difficult to remove, use the driven pulley puller [B].
- Install the attachment [C] as shown.

**Special Tool - Driven Pulley Puller: 57001-1920**

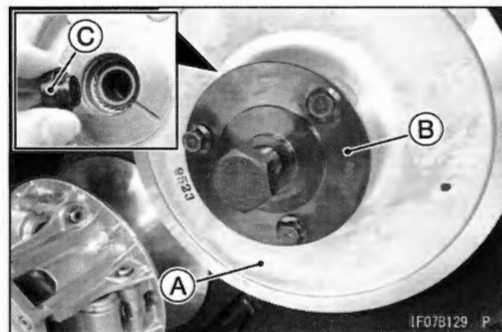
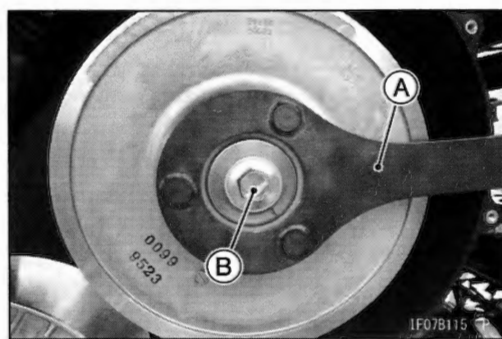

### Driven Pulley Installation

- Clean the driven shaft [A].

#### NOTE

○When engaging the spline on the driven pulley with the spline [B] on the shaft, do not damage the pulley's spline. If any damage occurs, remove it with a file.

- Apply grease (WR500-No.2 (KYODO YUSHI), POWER LITE WR #2 (KYODO YUSHI), or SERAN-HV (TOTAL FINA)) to the spline of the driven shaft and the inner surfaces [C] of the driven pulley [D].

- Install:  
Driven Pulley [A]
- Wipe off the excess grease [B].
- Install washer [C] on the driven shaft as shown.

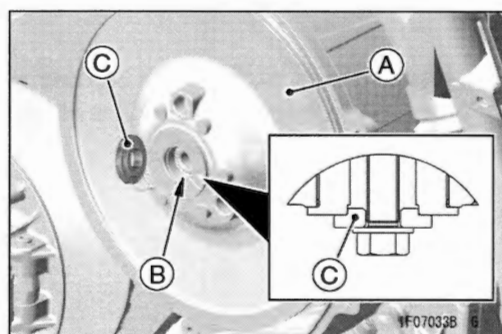
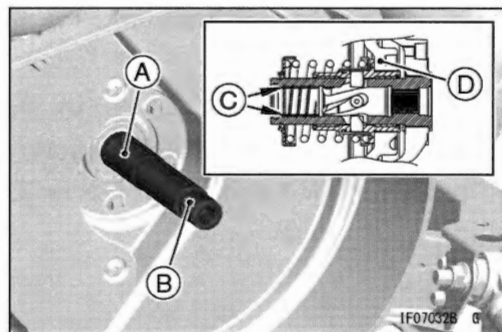

## 6-16 CONVERTER SYSTEM/CLUTCH

### Driven Pulley

- Using the driven pulley holder [A], tighten the driven pulley bolt [B].

**Special Tool - Driven Pulley Holder: 57001-1918**

#### NOTE

○The driven pulley bolt has left-hand threads.

**Torque - Driven Pulley Bolt: 135 N·m (13.8 kgf·m, 100 ft·lb)**

- Wipe the excess grease off the driven shaft.

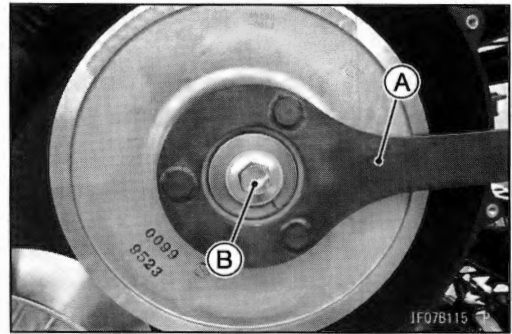

### Driven Pulley Disassembly

- Remove:  
Driven Pulley (see Driven Pulley Removal(6-15))
- Hold the driven pulley spring compressor in a vise.

**Special Tool - Driven Pulley Spring Compressor: 57001-1921**

- Set the driven pulley onto the driven pulley spring compressor.
- Install:  
Spring Holder [A]  
Nut [B]
- Tighten the nut, and compress the spring with the spring holder.
- Remove the circlip [A] with circlip pliers [B].  
**Special Tool - Outside Circlip Pliers: 57001-144**
- Remove the nut and spring holder [C].

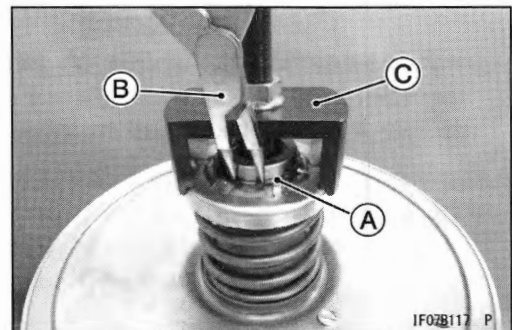
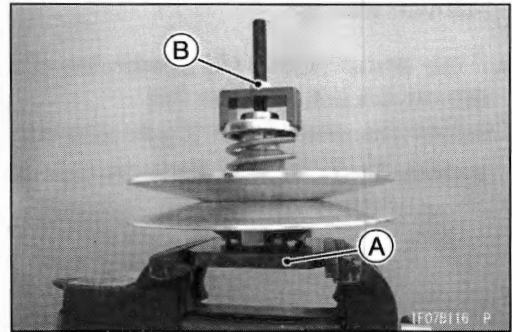

- ★ The spring seat [A] may not lift even if the nut [B] loosens.  
○Then tap the spring seat with a plastic mallet [C] lightly to release the stuck spring.

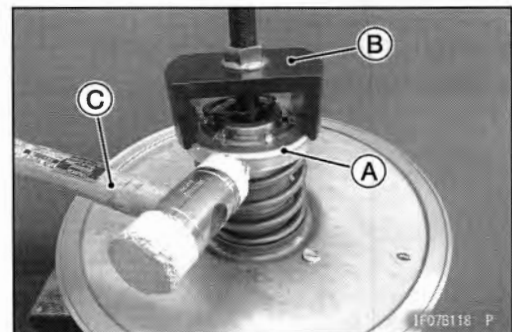

## Driven Pulley

- Remove:  
Spring Seats [A]  
Spring [B]

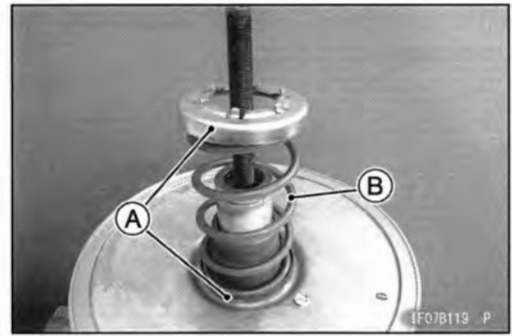

- Wipe off the molybdenum disulfide grease.
- Remove the four pins [A] with a thin flat tip screwdriver [B].
- Remove the movable sheave from the fixed sheave.

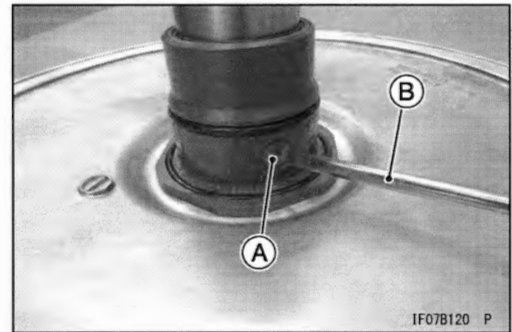

### Driven Pulley Inspection

- Check the sheave with uneven wear on the belt contacting surfaces.  
Sheave Surface [A]  
Straight Edge [B]

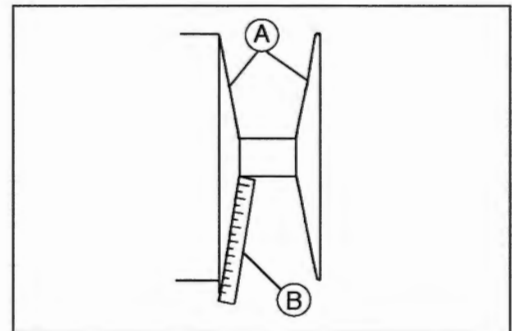

- ★ If the sheave surfaces [A] are uneven wear or damaged, replace the sheaves as a set.

#### NOTE

○ The movable sheave and fixed sheave are balanced as a set, so both sheaves must be replaced as a set.

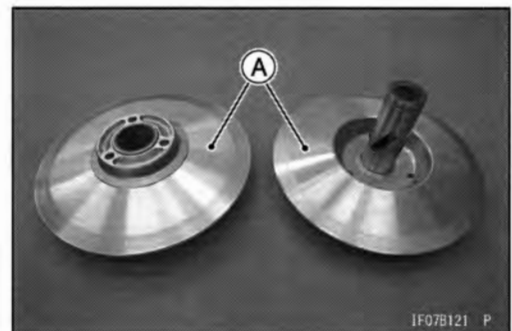

- ★ If the sheave bushings [A] are damaged or worn, replace the sheaves as a set.

#### Sheave Bushing Inside Diameter

Standard: 45.000 ~ 45.085 mm (1.7716 ~ 1.7750 in.)

Service Limit: 45.3 mm (1.78 in.)

- Inspect seals for damage.
- ★ If seals are damaged, replace the sheaves as a set.

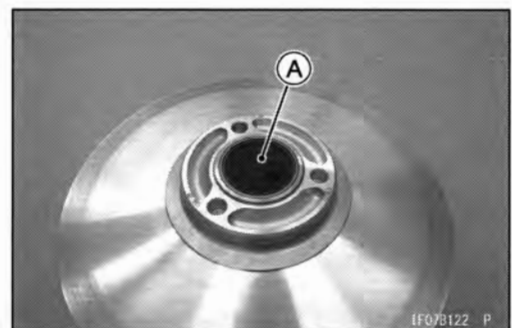

## 6-18 CONVERTER SYSTEM/CLUTCH

### Driven Pulley

★ If the splines [A] are damaged or worn, replace the sheaves as a set.

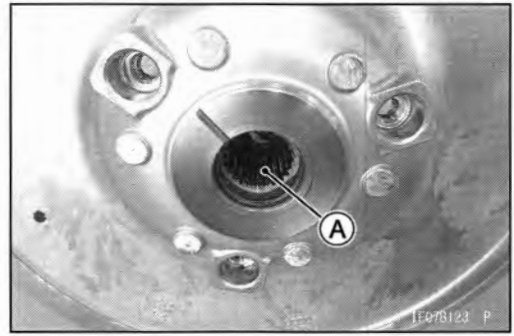

★ If the spring is damaged or worn, replace the spring.

#### Spring Free Length [A]

Standard: 97.5 mm (3.84 in.)

★ If the spring coils are distorted, replace the spring.

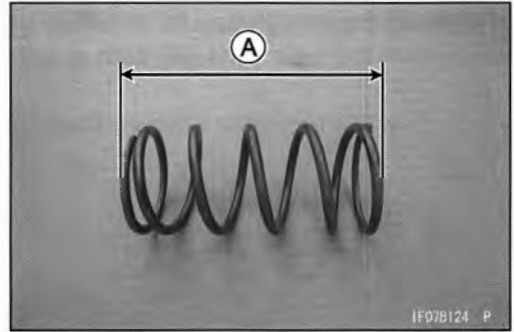

### Driven Pulley Assembly

● Clean off any grease or dirt on the movable and fixed sheaves, and dry them with a clean cloth.

● Visually inspect the bushings [A].

★ If the bushings is damaged or badly worn, replace them.

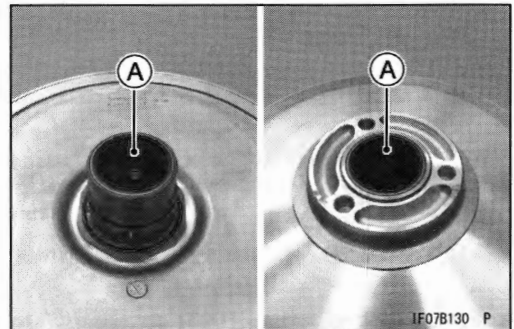

● Press the bushings [A] until they are bottomed.

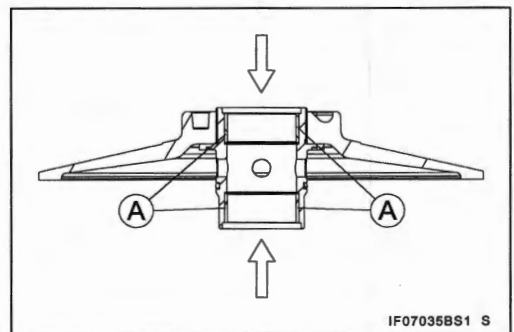

## Driven Pulley

- Press the oil seals [A] in the movable sheave assembly so that the oil seal surface is flush [B] with the sheave end.
- Apply grease to the oil seal lips [C].
- Apply grease (WR500-No.2 (KYODO YUSHI), POWER LITE WR #2 (KYODO YUSHI), or SERAN-HV (TOTAL FINA)) to the inner surfaces [D] of the bushings.

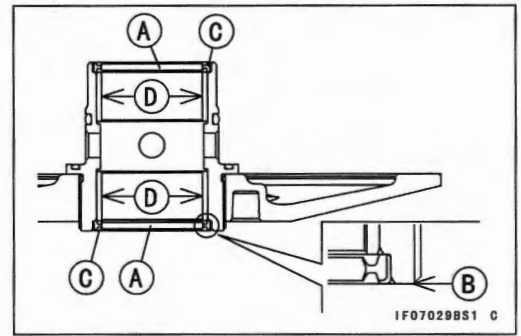

- Align the paint mark "0" [A] on the movable sheave [B] with the point [C] on the fixed sheave [D] for phase fit of the sheaves.

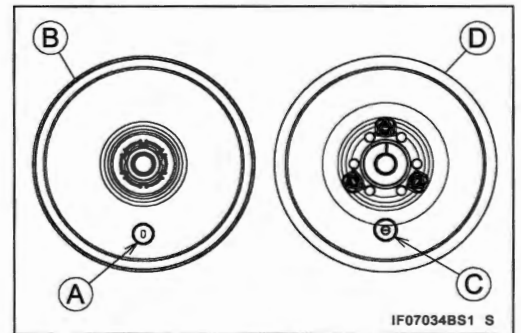

- Wrap the groove [A] for the circlip on the shaft with a tape [B] to protect the seals from damage.
- Insert the movable sheave to the fixed sheave, aligning the opening [C] with the hole [D].

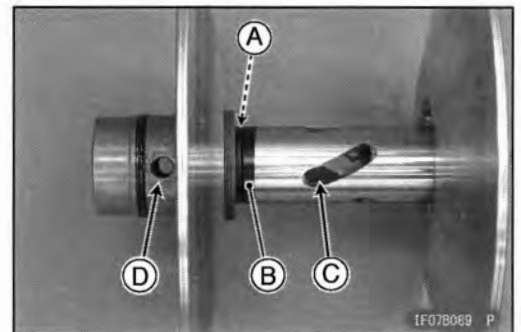

- Apply grease (WR500-No.2 (KYODO YUSHI), POWER LITE WR #2 (KYODO YUSHI), or SERAN-HV (TOTAL FINA)) to the seating surface of the pins [A], and insert them into the holes [B] in the movable sheave.

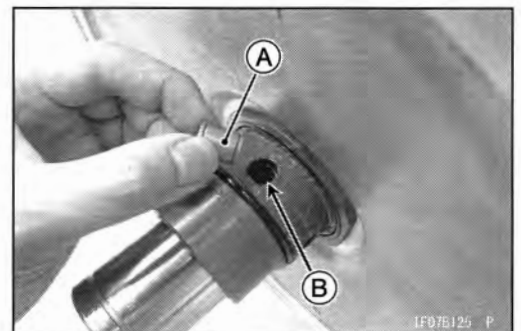

- Check that the O-rings [A] are in good condition.
- ★ If any of the O-rings are damaged, replace them.
- Apply grease to the O-rings.



## 6-20 CONVERTER SYSTEM/CLUTCH

### Driven Pulley

- Hold the driven pulley spring compressor in a vise.  
**Special Tool - Driven Pulley Spring Compressor: 57001-1921**
- Set the driven pulley [A] onto the driven pulley spring compressor.
- Install:
  - Spring Seat [B]: (Gray)
  - Spring [C]
  - Spring Seat [D]: (Silver)
  - New Circlip [E]
- Tighten the nut [A], and compress the spring with the spring holder [B].
- Install the circlip [C] with circlip pliers [D].  
**Special Tool - Outside Circlip Pliers: 57001-144**
- Remove the driven pulley from the driven pulley spring compressor.
- Clean the surface of the sheaves with an oil-less cleaning fluid.
- Install:  
Driven Pulley (see Driven Pulley Installation(6-15))

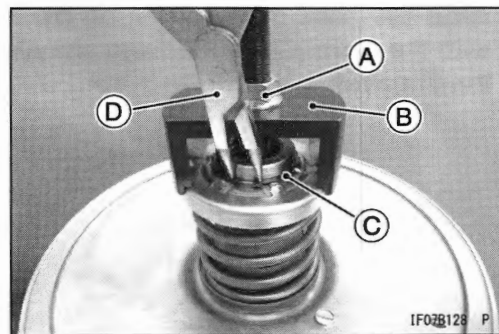
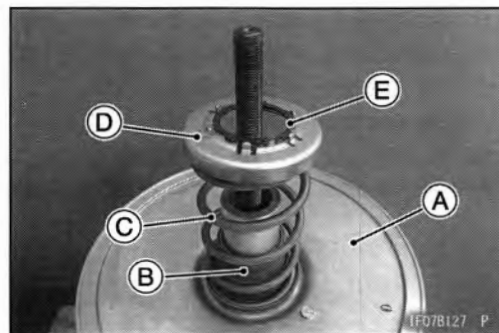

## Torque Converter Housing

### Torque Converter Housing Removal

- Remove:
  - Drive Pulley (see Drive Pulley Removal(6-12))
  - Driven Pulley (see Driven Pulley Removal(6-15))
  - Air Vent Cover Screws [A]
  - Air Vent Cover [B]
  
- Disconnect the intake air temperature sensor lead connector [A].
- Free the leads from the clamps [B].
- Loosen the clamp screw [C].
  
- Remove:
  - Torque Converter Housing Bolts [A]
  - Torque Converter Housing [B]
  - O-ring
  
- Remove:
  - Lower CVT Intake Duct Bolts [A]
  - Lower CVT Intake Duct [B]
  - Clamps [C]

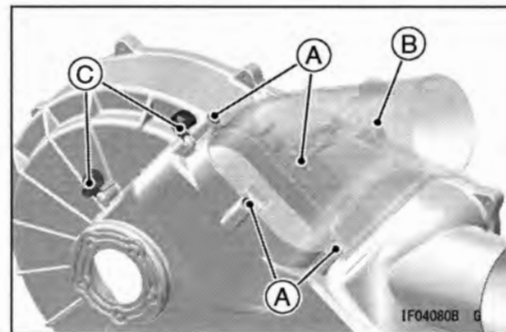
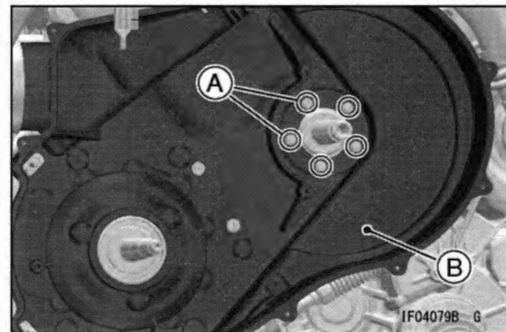
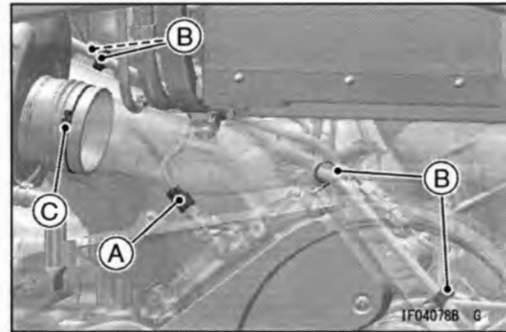
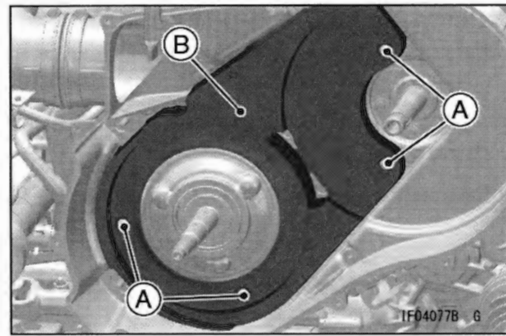

### Torque Converter Housing Installation

- Install the clamps [A] and screws [B] to the torque converter housing.

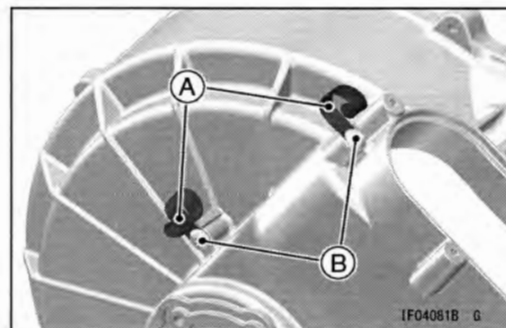

## 6-22 CONVERTER SYSTEM/CLUTCH

### Torque Converter Housing

- Using a high flash-point solvent, clean off any oil or dirt that may be on the liquid gasket coating area. Dry them with a clean cloth.
- Apply liquid gasket to the mating surface [A] of the torque converter housing.

Sealant - Liquid Gasket, TB1216: 92104-1063

#### NOTE

○When the liquid gasket is applied to the parts, finish part assembling before the liquid gasket starts curing (within 6 minutes after the liquid gasket is applied).

- Fit the lower CVT intake duct [A] to the torque converter housing.
- Install:  
Lower CVT Intake Duct Screw [B]

- Check to see that the trim seals [A] and the collars [B] are in place.

- Replace the O-ring [A] with a new one.
- Apply grease to the O-ring.
- Install:  
O-ring  
Torque Converter Housing

- Tighten:  
**Torque - Torque Converter Housing Bolts [A]: 9.0 N·m (0.92 kgf·m, 80 in·lb)**
- Install:  
Air Vent Cover [B]  
Air Vent Cover Screws [C]
- Install the removed parts.

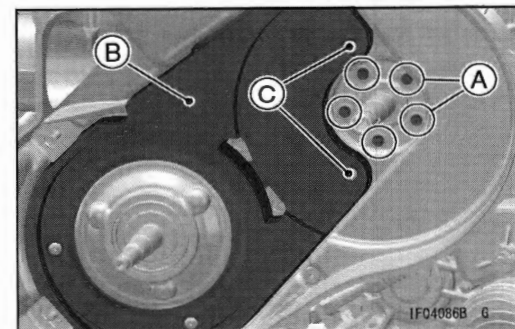
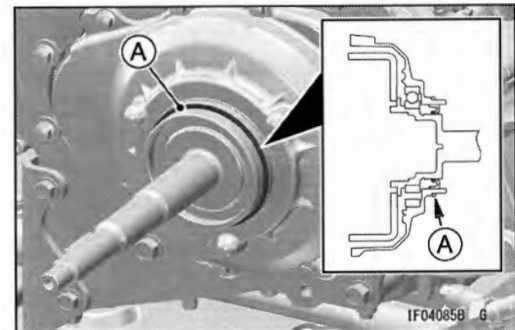
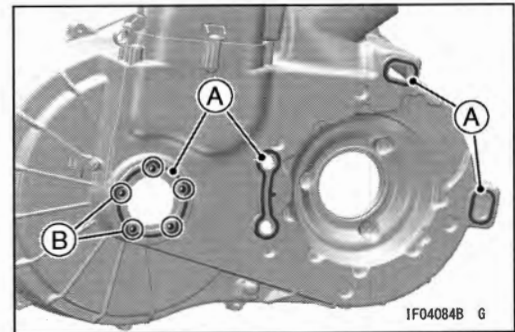
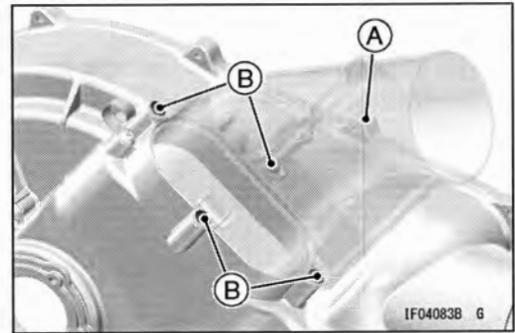
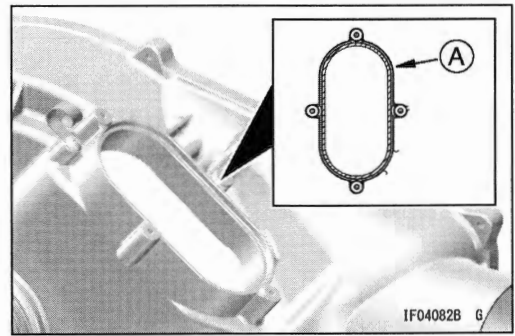

## Torque Converter Housing

### Clutch Cover Removal

- Remove:
  - Torque Converter Housing (see [Torque Converter Housing Removal\(6-21\)](#))
- Free the clamps [A] from the engine side plate [B].
- Remove:
  - Propeller Shaft Bearing Case Bolts [C]
  - Propeller Shaft Bearing Case Bracket Bolts [D] and Nuts
  - Propeller Shaft Bearing Case Bracket [E]
  - Engine Side Plate Bolts [F]
  - Engine/Transmission Case Bracket Bolt (M8) [G]
  - Clutch Cover Bolts [H] and Washers
  - Engine Side Plate
- Remove:
  - Clutch Cover Bolts [A]
  - Clutch Cover [B]

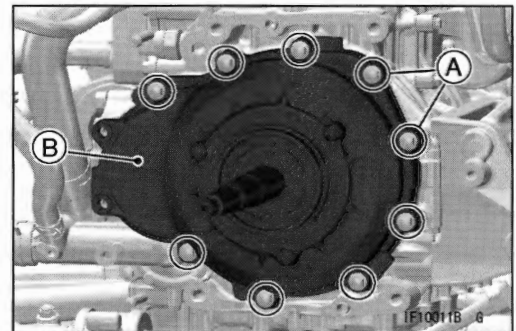
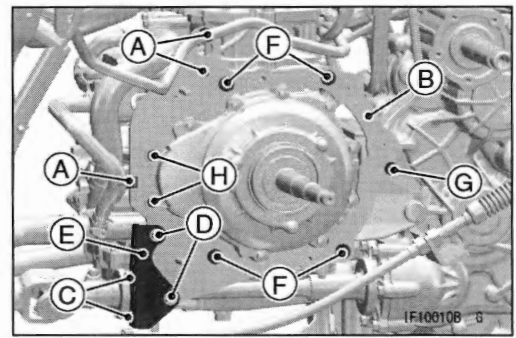

### Clutch Cover Installation

- When installing the stud bolts [A] and dowel pins [B] to engine side plate [C], install them as shown.

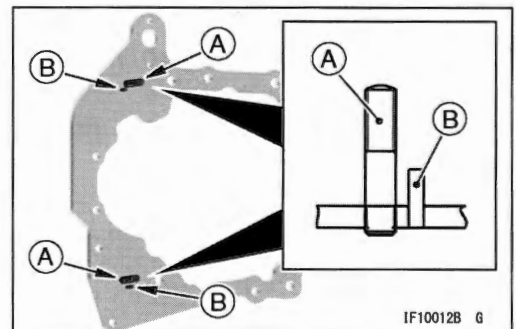

- Using a high flash-point solvent, clean off any oil or dirt that may be on the liquid gasket coating area. Dry them with a clean cloth.
- Apply liquid gasket to the area [A] where the mating surface of the crankcase touches the clutch cover gasket.

**Sealant - Liquid Gasket, TB1211F: 92104-0004**

- Be sure to dowel pins [B] are in position.
- Replace the clutch cover gasket with a new one and install it.

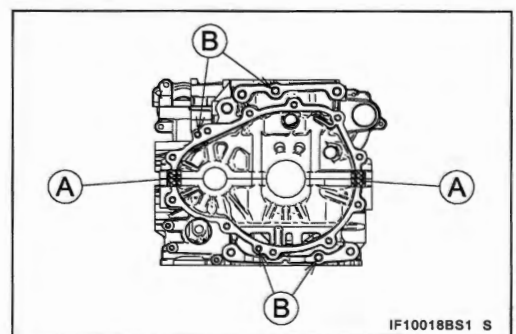

# 6-24 CONVERTER SYSTEM/CLUTCH

## Torque Converter Housing

- Install:

- Clutch Cover [A]
- Engine Side Plate [B]
- Clutch Cover Bolts [C]
- Clutch Cover Bolts [D] and Washers
- Engine/Transmission Case Bracket Bolt (M8) [E]
- Engine Side Plate Bolts [F]

- Tighten:

- Torque - Clutch Cover Bolts: 20 N·m (2.0 kgf·m, 15 in·lb)**
- Engine/Transmission Case Bracket Bolt (M8): 25 N·m (2.5 kgf·m, 18 in·lb)**
- Engine Side Plate Bolts: 40 N·m (4.1 kgf·m, 30 in·lb)**

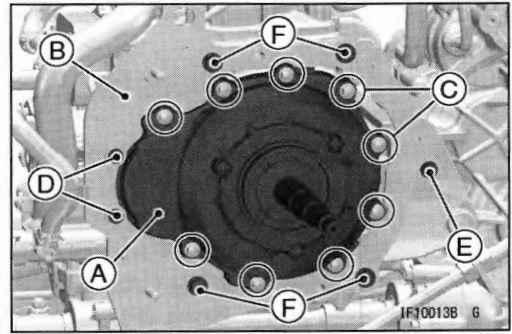

- Install:

- Propeller Shaft Bearing Case Bracket [A]
- Propeller Shaft Bearing Case Bracket Bolts [B] and Nuts
- Propeller Shaft Bearing Case Bolts [C]

- Tighten:

- Torque - Propeller Shaft Bearing Case Bracket Bolts: 25 N·m (2.5 kgf·m, 18 in·lb)**
- Propeller Shaft Bearing Case Bolts: 25 N·m (2.5 kgf·m, 18 in·lb)**

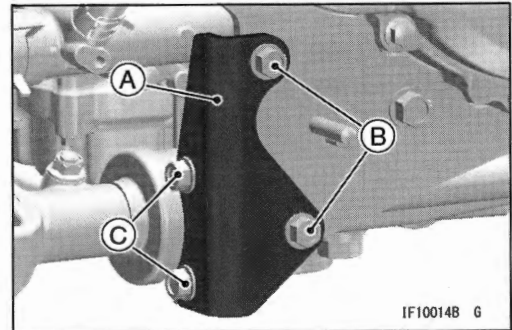

- Install the removed parts.

### ***Clutch Cover Disassembly***

- Remove:

- Torque Converter Housing (see Torque Converter Housing Removal(6-21))
- Oil Seal [A]

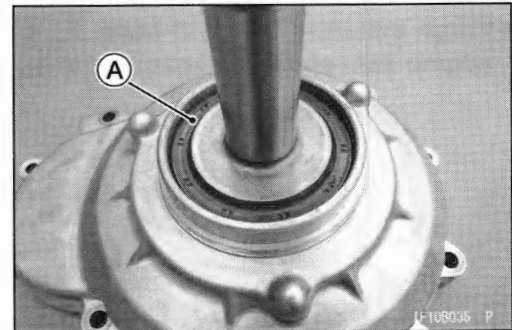

- Remove the circlip [A].

- Special Tool - Outside Circlip Pliers [B]: 57001-144**

- Remove the spacer [C].

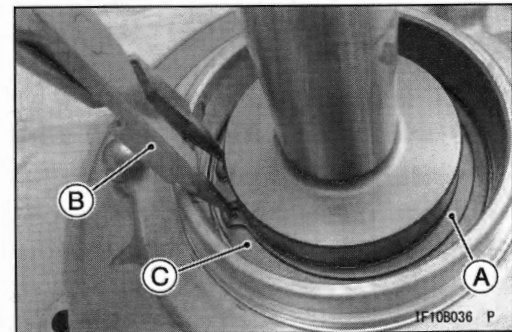

## Torque Converter Housing

- Remove the clutch housing [A] from the torque converter housing [B] using the clutch housing remover [C] and press [D].

**Special Tool - Clutch Housing Remover: 57001-1925**

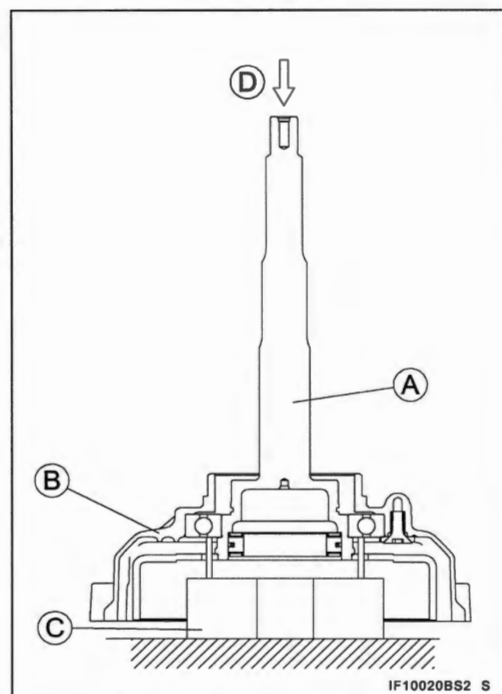

- Remove:
  - Clutch Cover Bearing Holder Bolts [A]
  - Clutch Cover Bearing Holder

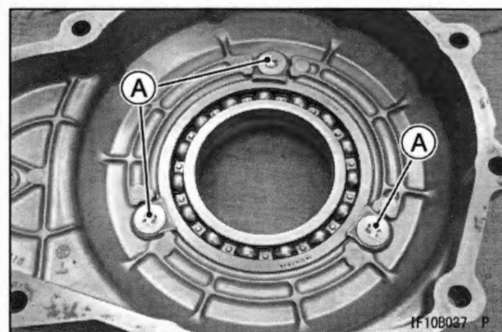

- Using the press, bearing driver [A] and steering stem bearing driver [B], remove the bearing.

**Special Tools - Steering Stem Bearing Driver,  $\phi 42.5$ : 57001-1344**

**Bearing Driver,  $\phi 76$ : 57001-1780**

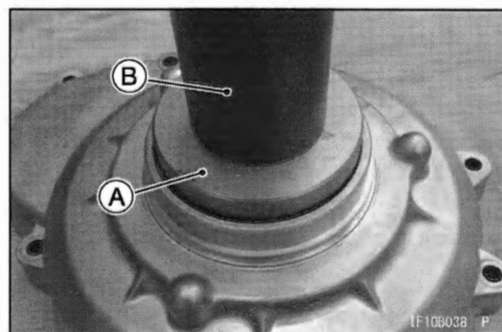

### Clutch Cover Assembly

- Replace the following parts with new ones.
  - Clutch Cover Bearing
  - Circlip
  - Oil Seal
- Press and insert the new bearing until bottomed.

**Special Tools - Bearing Driver Set [A]: 57001-1129**

**Clutch Housing Remover [B]: 57001-1779**

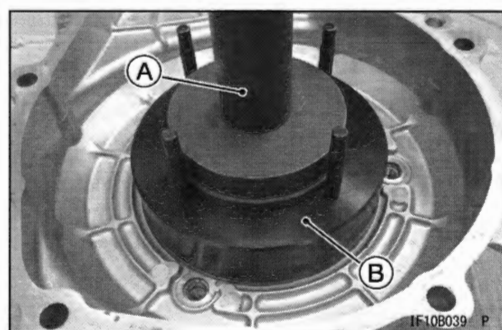

# 6-26 CONVERTER SYSTEM/CLUTCH

## Torque Converter Housing

- Install the clutch cover bearing holder [A] direction as shown.
- Apply a non-permanent locking agent to the clutch cover bearing holder bolts [B], and tighten them.

**Torque - Clutch Cover Bearing Holder Bolts: 15 N·m (1.5 kgf·m, 11 ft·lb)**

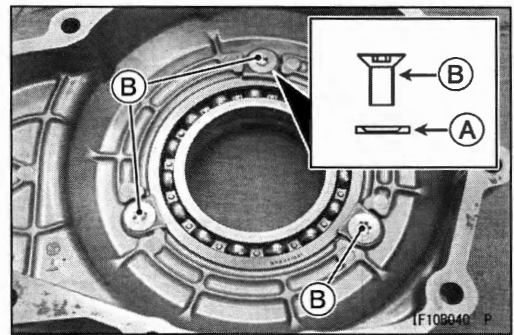

- When installing the one-way clutch [A] to the clutch housing.
- Put the one-way clutch in the clutch housing with the rotation mark [B] facing out.
- Apply engine oil to the one-way clutch.

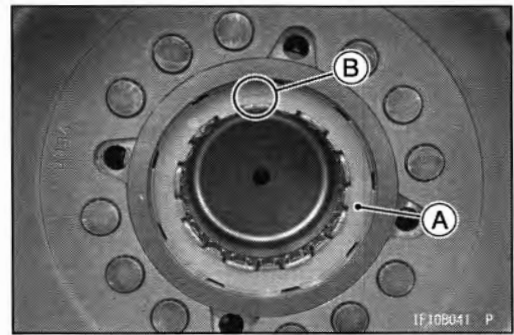

- Press [A] and install the clutch cover [B] with the ball bearing to the clutch housing [C] using the steering stem bearing driver [D] and bearing driver [E].

**Special Tools - Steering Stem Bearing Driver,  $\phi 42.5$ : 57001-1344**

**Bearing Driver,  $\phi 76$ : 57001-1780**

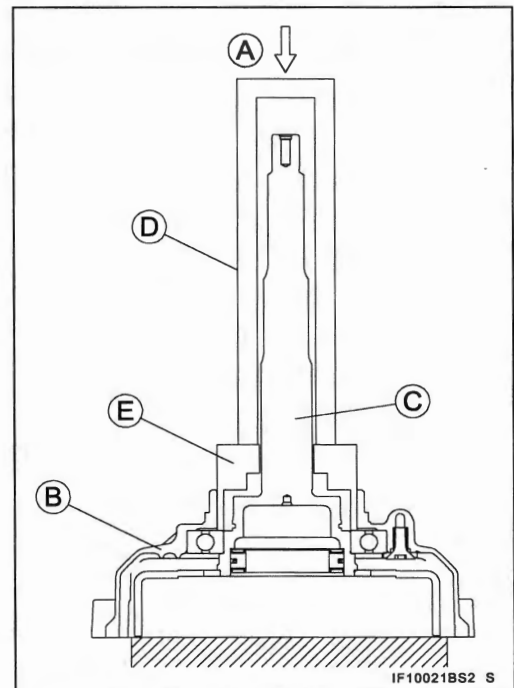

- Install:  
Spacer  
New Circlip

**Special Tool - Outside Circlip Pliers: 57001-144**

- Apply grease to the new oil seal lips.
- Press in the oil seal [A] in the clutch cover as shown.  
6.3 mm (0.25 in.) [B] or less
- Wipe the excess grease off the oil seal and the clutch housing.
- Install the removed parts.

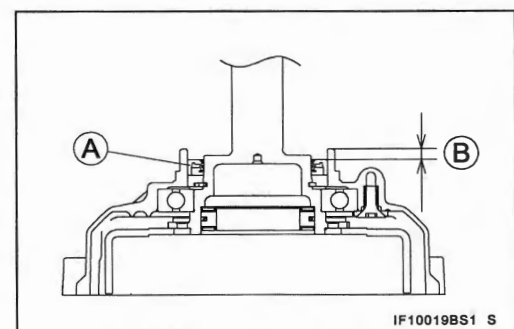

## Clutch

### Clutch Removal

- Remove:
  - Clutch Cover (see Clutch Cover Removal(6-23))
- Hold the clutch [A].
  - Special Tool - Clutch Holder [B]: 57001-1922**
- Remove:
  - Clutch Hub Bolts [C]
  - Clutch

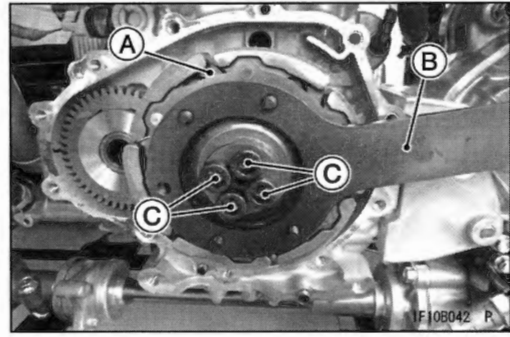

### Clutch Installation

- Check to see that the dowel pins [A] are in place.
- Apply molybdenum disulfide oil solution to the seating surface and threads of the clutch hub bolts.

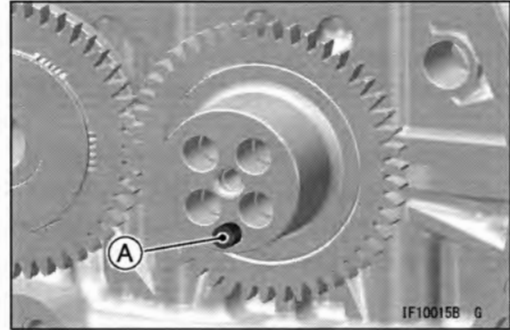

- Install:
  - Clutch [A]
  - Clutch Hub Bolts [B]
- Hold the clutch.
  - Special Tool - Clutch Holder [C]: 57001-1922**
- Tighten the clutch hub bolts following the specified tightening sequence [1 ~ 4].
  - Torque - Clutch Hub Bolts: 127 N·m (13.0 kgf·m, 93.7 ft·lb)**

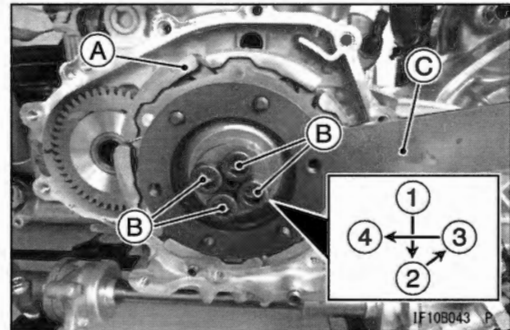

### Clutch Shoe Lining Wear Inspection

- Remove the clutch (see Clutch Removal(6-27)).
- Visually inspect the clutch shoe linings [A] for uneven wear, discoloration, missing friction material, cracks or other damage.
- ★ If any of the linings are damaged, replace the clutch.

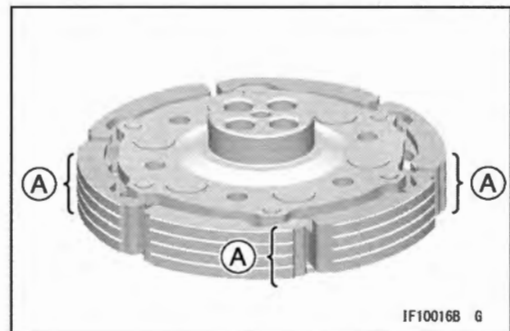

- Measure the groove depth [A].
  - Use a depth gauge, and measure at several points as shown.
  - ★ If any measurement is less than the service limit, replace the clutch.

#### Clutch Shoe Groove Depth

- Standard: 1.0 mm (0.039 in.)**
- Service Limit: 0.5 mm (0.02 in.)**

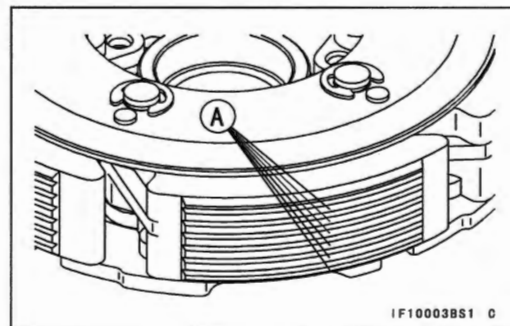

## 6-28 CONVERTER SYSTEM/CLUTCH

### Clutch

#### **One-Way Clutch Inspection**

- Remove the drive belt (see [Drive Belt Removal\(6-10\)](#)).
- Turn the clutch housing by hand. When view from the left side of the engine, the clutch housing should turn clockwise freely [A] but should not turn counterclockwise.

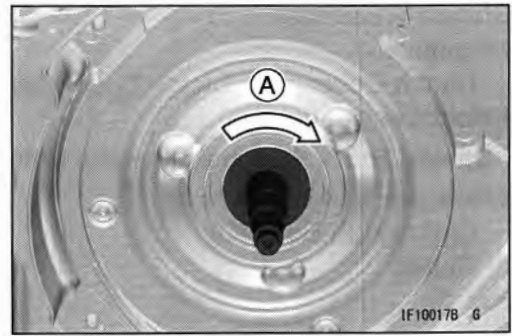

- ★ If the one-way clutch does not operate as it should or if it makes noise, go to the next steps.
- Remove the clutch cover (see [Clutch Cover Removal\(6-23\)](#)).
- Check that the one-way clutch [A] is installed so that the rotation mark [B] faces to the clutch.
- Visually inspect the one-way clutch in the clutch housing.
- ★ If there is any worn or damaged part, replace it.

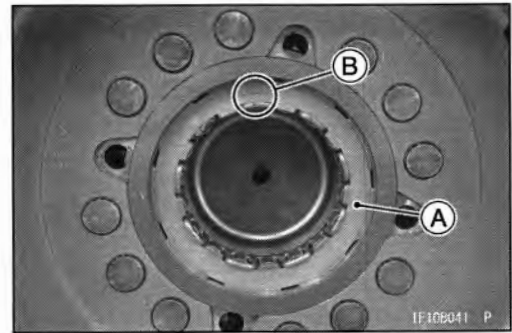

**Converter Duct**

**CVT Pre Filter Removal**

- Remove:
  - Quick Rivets [A]
  - CVT Pre Filter [B]

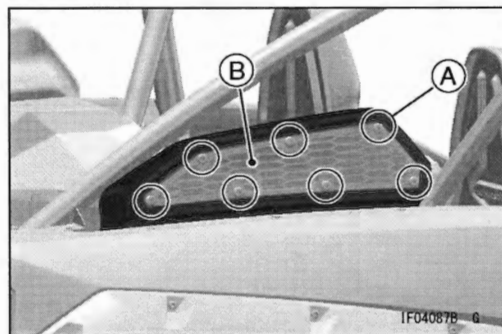

**CVT Pre Filter Installation**

- Installation is the reverse of removal.

**CVT Pre Filter Inspection**

- Remove:
  - CVT Pre Filter (see CVT Pre Filter Removal(6-29))
- Clean and inspect the pre filter.
- ★ If the pre filter is damaged, replace it with a new one.

**CVT Pre Filter Housing Removal**

- Remove:
  - Front Cargo Bed Cover (see Front Cargo Bed Cover Removal(16-35))
  - Quick Rivets [A]

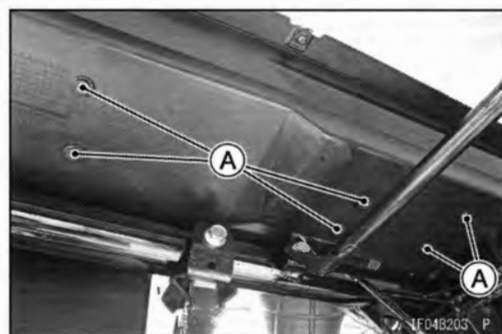

- Loosen the clamp screw [A].



- Remove:
  - CVT Pre Filter Housing [A]

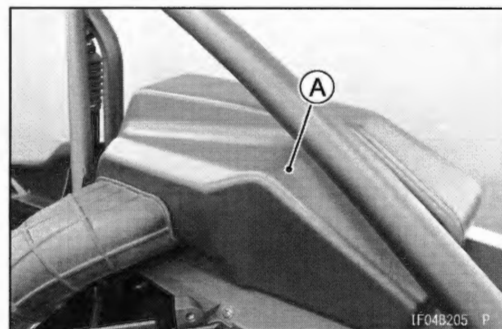

**CVT Pre Filter Housing Installation**

- Installation is the reverse of removal.

# 6-30 CONVERTER SYSTEM/CLUTCH

## Converter Duct

### Upper CVT Intake Duct Removal

- Remove:
  - Front Cargo Bed Cover (see Front Cargo Bed Cover Removal(16-35))
  - Screw [A] and Washer

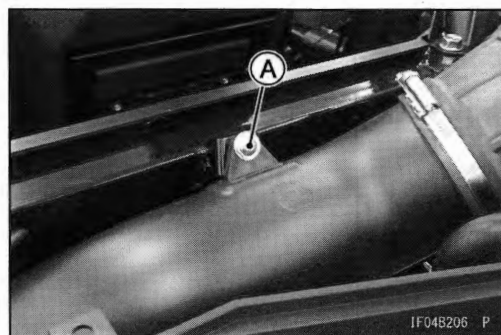

- Loosen the clamp screws [A].
- Remove:
  - Upper CVT Intake Duct [B]

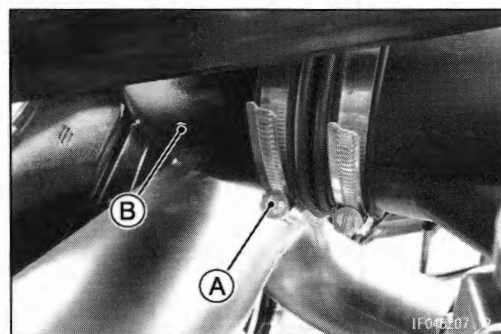

### Upper CVT Intake Duct Installation

- Installation is the reverse of removal.

### CVT Exhaust Duct Removal

- Remove:
  - Upper CVT Intake Duct (see Upper CVT Intake Duct Removal(6-30))
  - Screw [A] and Washer



- Loosen the clamp screw [A].
- Disconnect the clamp [B] from the CVT exhaust duct [C].
- Remove:
  - CVT Exhaust Duct

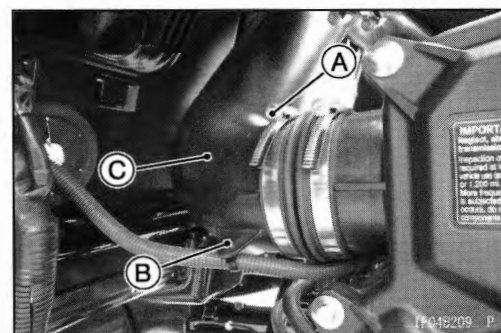

### CVT Exhaust Duct Installation

- Installation is the reverse of removal.