

# CHAPTER 6

## PVT SYSTEM

GENERAL INFORMATION.....	6.2
SPECIAL TOOLS .....	6.2
2022 RZR PRO R CLUTCH CHART .....	6.2
2022 RZR PRO R 4 CLUTCH CHART .....	6.2
PVT SYSTEM OVERVIEW.....	6.3
GENERAL OPERATION .....	6.3
DRIVE CLUTCH OPERATION .....	6.3
DRIVEN CLUTCH OPERATION.....	6.3
DRIVE BELT .....	6.4
BELT REMOVAL.....	6.4
BELT INSPECTION.....	6.4
BELT INSTALLATION.....	6.5
BELT BREAK-IN.....	6.6
DRIVE CLUTCH SERVICE .....	6.7
DRIVE CLUTCH REMOVAL .....	6.7
DRIVE CLUTCH ASSEMBLY VIEW .....	6.8
CLUTCH DISASSEMBLY .....	6.10
BEARING INSPECTION .....	6.10
BUTTON TO TOWER CLEARANCE INSPECTION .....	6.11
SPIDER REMOVAL.....	6.11
ROLLER, PIN, AND THRUST WASHER INSPECTION .....	6.11
ROLLER REPLACEMENT .....	6.12
SHIFT WEIGHT INSPECTION .....	6.12
CLUTCH INSPECTION .....	6.13
DRIVE CLUTCH SPRING INSPECTION .....	6.14
DRIVE CLUTCH BUSHINGS INSPECTION .....	6.14
BUSHING SERVICE .....	6.15
CLUTCH ASSEMBLY .....	6.17
DRIVE CLUTCH INSTALLATION.....	6.18
DRIVEN CLUTCH SERVICE.....	6.20
DRIVEN CLUTCH REMOVAL .....	6.20
DRIVEN CLUTCH ASSEMBLY VIEW .....	6.21
DRIVEN CLUTCH DISASSEMBLY .....	6.22
HELIX AND MOVABLE SHEAVE BUSHING INSPECTION.....	6.23
BUSHING SERVICE .....	6.23
DRIVEN CLUTCH ASSEMBLY.....	6.24
DRIVEN CLUTCH INSTALLATION .....	6.25
DRIVEN CLUTCH ALIGNMENT.....	6.26

## GENERAL INFORMATION

### SPECIAL TOOLS

PART NUMBER	TOOL DESCRIPTION
PU-50518-A	Drive Clutch Compressor
PU-52422	Drive Clutch Puller
PU-50578	Spider Jam Nut Socket
PU-52944	Drive Clutch Holding Tool

**Bosch Automotive Service Solutions:** 1-800-345-2233 or <http://polaris.service-solutions.com>

### 2022 RZR PRO R CLUTCH CHART

MODEL	ALTITUDE	SHIFT WEIGHT	DRIVE SPRING	DRIVEN SPRING
2022 RZR PRO R	0-1800 Meters (0-6000 Feet)	W-34-112 (1323597)	Black (7045112)	Black (7045138)
	1800-3700 Meters (6000-12000 Feet)	W-34-104 (1323586)		

### 2022 RZR PRO R 4 CLUTCH CHART

MODEL	ALTITUDE	SHIFT WEIGHT	DRIVE SPRING	DRIVEN SPRING
2022 RZR PRO R 4	0-1800 Meters (0-6000 Feet)	W-34-112 (1323746)	Black (7045112)	Black (7045138)
	1800-3700 Meters (6000-12000 Feet)	W-34-104 (1323586)		

## PVT SYSTEM OVERVIEW

### GENERAL OPERATION

#### WARNING

All PVT maintenance or repairs should be performed by a certified Polaris Master Service Dealer (MSD) technician who has received the proper training and understands the procedures outlined in this manual.

**Because of the critical nature and precision balance incorporated into the PVT components, it is absolutely essential that no disassembly or repair be made without factory authorized special tools and service procedures.**

The Polaris Variable Transmission (PVT) consists of three major assemblies:

- 1) The Drive Clutch
- 2) The Driven Clutch
- 3) The Drive Belt

The internal components of the drive clutch and driven clutch control engagement (initial vehicle movement), clutch upshift and backshift. During the development of the Polaris vehicle, the PVT system is matched first to the engine power curve; then to average riding conditions and the vehicle's intended usage. Therefore, modifications or variations of components at random are never recommended. Proper clutch setup and careful inspection of existing components must be the primary objective when troubleshooting and tuning.

### DRIVE CLUTCH OPERATION

Drive clutches primarily sense engine RPM. The two major components which control its shifting function are the shift weights and the coil spring. Whenever engine RPM is increased, centrifugal force is created, causing the shift weights to push against rollers on the moveable sheave, which is held open by coil spring preload. When this force becomes higher than the preload in the spring, the outer sheave moves inward and contacts the drive belt. This motion pinches the drive belt between the spinning sheaves and causes it to rotate, which in turn rotates the driven clutch.

At lower RPM, the drive belt rotates low in the drive clutch sheaves. As engine RPM increases, centrifugal force causes the drive belt to be forced upward on drive clutch sheaves.

### DRIVEN CLUTCH OPERATION

Driven clutches primarily sense torque, opening and closing according to the forces applied to it from the drive belt and the transmission input shaft. If the torque resistance at the transmission input shaft is greater than the load from the drive belt, the drive belt is kept at the outer diameter of the driven clutch sheaves.

As engine RPM and horsepower increase, the load from the drive belt increases, resulting in the belt rotating up toward the outer diameter of the drive clutch sheaves and downward into the sheaves of the driven clutch. This action, which increases the driven clutch speed, is called upshifting.

Should the throttle setting remain the same and the vehicle is subjected to a heavier load, the drive belt rotates back up toward the outer diameter of the driven clutch and downward into the sheaves of the drive clutch. This action, which decreases the driven clutch speed, is called backshifting.

In situations where loads vary (such as uphill and downhill) and throttle settings are constant, the drive and driven clutches are continually shifting to maintain optimum engine RPM. At full throttle a perfectly matched PVT system should hold engine RPM at the peak of the power curve. This RPM should be maintained during clutch upshift and backshift. In this respect, the PVT system is similar to a power governor. Rather than vary throttle position, as a conventional governor does, the PVT system changes engine load requirements by either upshifting or backshifting.

### DRIVE BELT BELT REMOVAL

1. Park vehicle on a level surface.
2. Remove seats. On 4-seat models, remove the rear seats.
3. Remove upper and lower rear close-off panels.
4. Loosen hose clamp ② and remove the PVT intake hose.

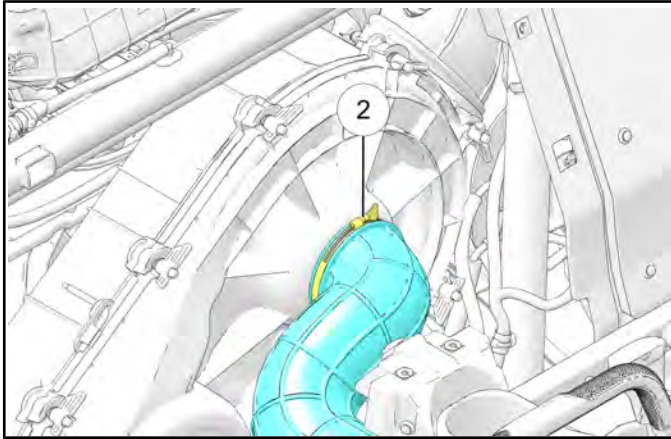

3. Belts with thin spots, burn marks, etc., should be replaced to eliminate noise, vibration, or erratic PVT operation. See the Troubleshooting Chart at the end of this chapter for possible causes.

5. Remove five fasteners ③, disengage remaining 1/4 turn latches, and remove the outer PVT cover.

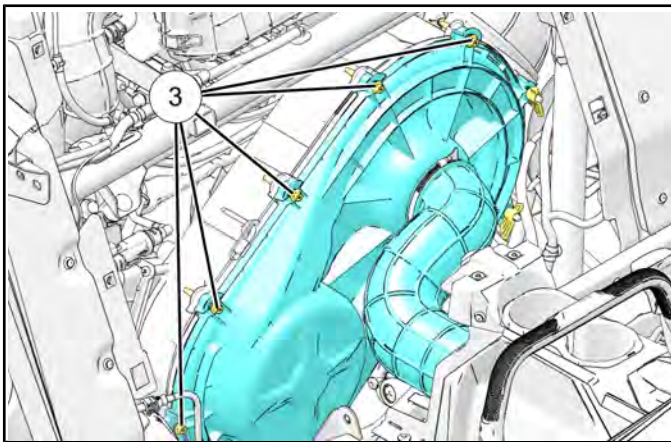

6. Remove the drive belt.

### BELT INSPECTION

1. Inspect belt for hour glassing (extreme circular wear in at least one spot and on both sides of the belt). Hour glassing occurs when the drive train does not move and the drive clutch engages the belt.
2. Inspect belt for loose cords, missing cogs, cracks, abrasions, thin spots, or excessive wear. Compare belt measurements with a new drive belt. Replace if necessary.

## BELT INSTALLATION

1. With the clutch spreader tool installed, loop the belt over the drive clutch and over part of the driven clutch. Be sure to install belt in the direction previously marked.
2. Rotate the driven clutch and walk the belt into the clutch.
3. Remove the clutch spreader tool from the driven clutch.
4. Rotate / spin the driven clutch and belt approximately 5-7 times to properly seat the belt in the driven clutch.
5. Install outer clutch cover. Install five fasteners<sup>③</sup> and engage 1/4 turn latches to secure the cover. Torque fasteners to specification.

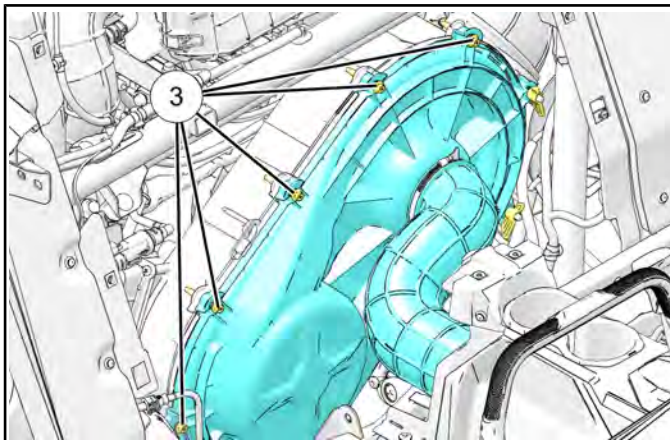

### TORQUE

Outer PVT Cover Fasteners:  
**60 in-lbs (7 Nm)**

6. Install clutch intake hose. Tighten hose clamp <sup>②</sup>. Torque hose clamp to specification.

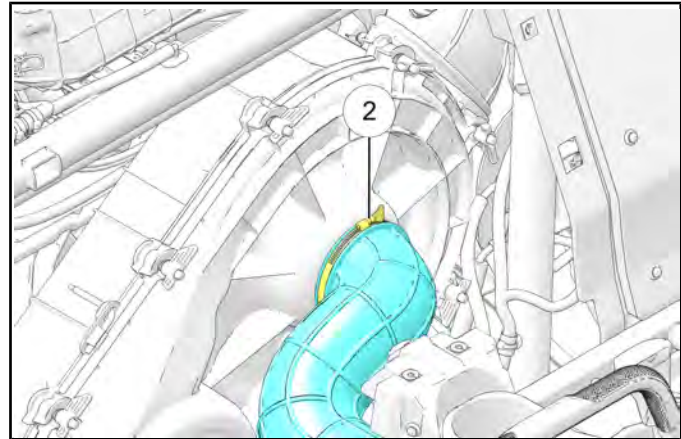

### TORQUE

PVT Intake Hose Clamp:  
**35 in-lbs (4 Nm)**

7. Install upper and lower rear close-off panels.
8. Install seats. On 4-seat models, install the rear seats.

### **BELT BREAK-IN**

A proper break-in of the clutches and drive belt will ensure a longer life and better performance. If a belt fails, always clean any debris from the duct and from the engine compartment.

#### **Standard Break-In**

Drive at slower speeds for the first 50 miles (80 km) of operation. Carry only light loads. Avoid aggressive acceleration, high-speed operation and prolonged operation at a specific RPM during this period.

#### **Sand/Dune Break-In**

Drive in low gear for the first 5 miles (8 km) of operation. Avoid prolonged low speed operation at high throttle. Avoid aggressive acceleration, high-speed operation and prolonged operation at a specific RPM during this period.

## DRIVE CLUTCH SERVICE

### DRIVE CLUTCH REMOVAL

1. Park vehicle on a level surface.
2. Remove seats. On 4-seat models, remove the rear seats.
3. Remove upper and lower rear close-off panels.
4. Loosen hose clamp ② and remove the PVT intake hose.

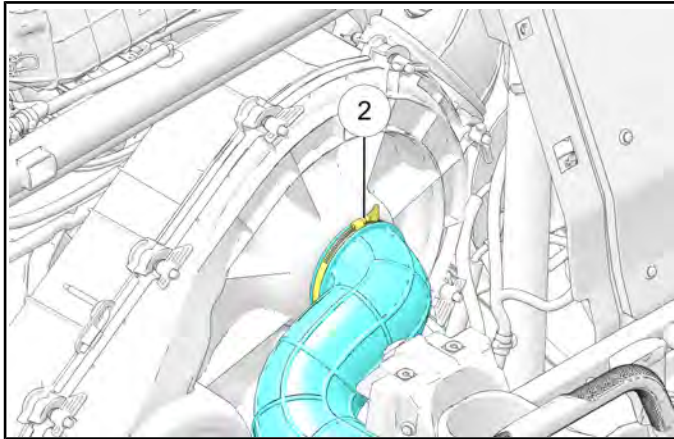

5. Remove five fasteners ③, disengage remaining 1/4 turn latches, and remove the outer PVT cover.

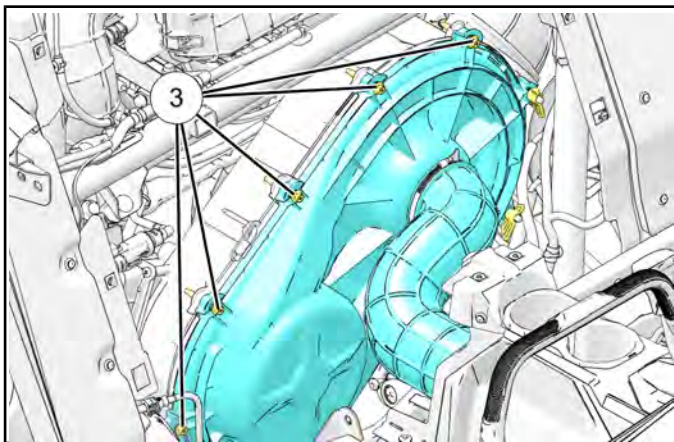

6. Remove the drive belt.

7. Remove drive clutch retaining bolt ⑦ and remove the drive clutch moveable-sheave assembly.

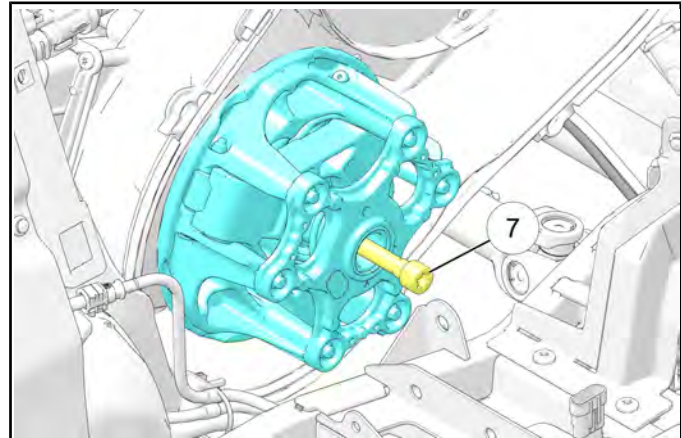

8. Remove the outer slip-fit post and install the Drive Clutch Puller (PN **PU-52422**) to remove the stationary sheave.

Drive Clutch Puller:  
**PU-52422**

6

**DRIVE CLUTCH ASSEMBLY VIEW**

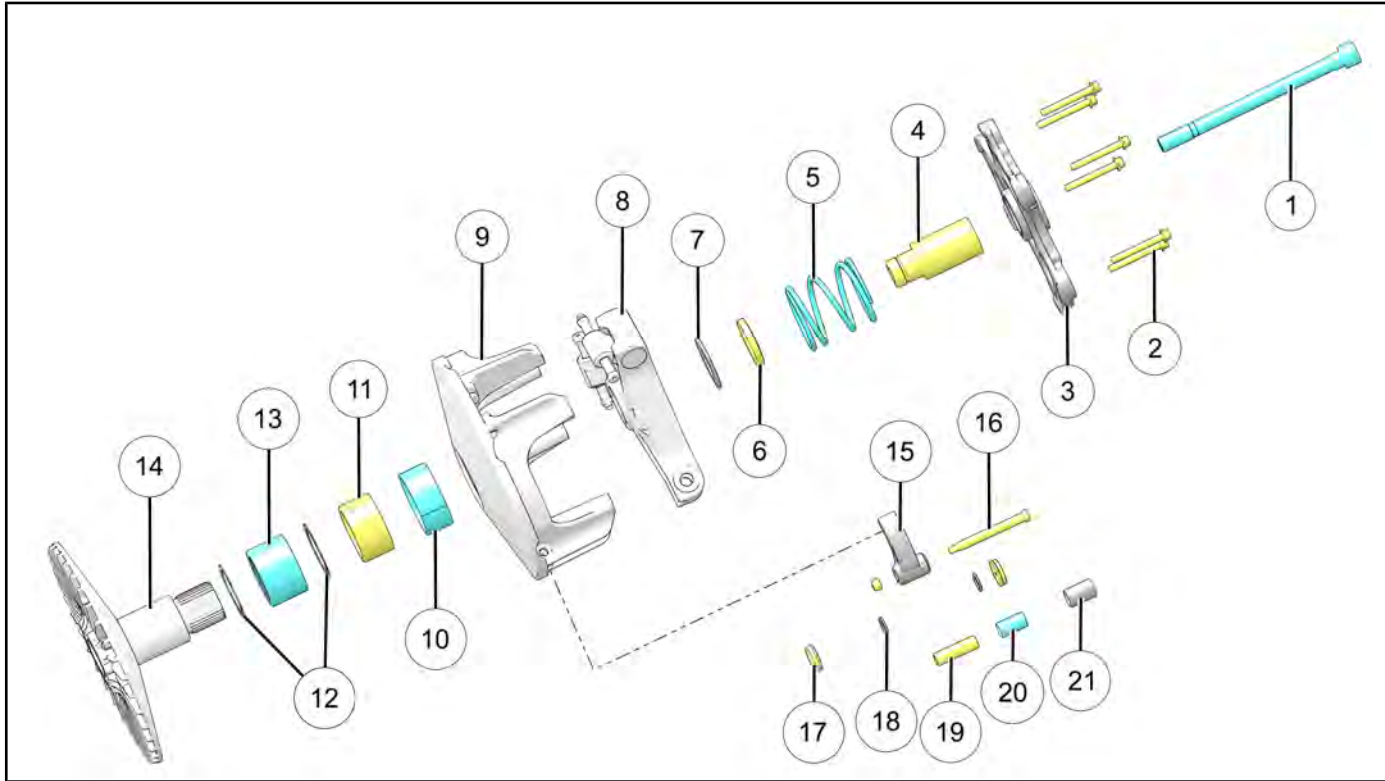

REF	DESCRIPTION	TORQUE
①	Clutch Bolt	<b>140 ft-lbs (190 Nm)</b>
②	Drive Clutch Cover Bolts	<b>15 ft-lbs (21 Nm)</b>
③	Drive Clutch Cover	-
④	Outer Clutch Post	-
⑤	Spring	-
⑥	Belleville Washer	Dome side facing outer post
⑦	Washer	-
⑧	Spider	-
⑨	Sheave Assembly	-
⑩	Bushing	-
⑪	Clutch Spacer	-
⑫	Washer	-
⑬	Needle Bearing	-
⑭	Stationary Sheave	-
⑮	Shift Weight	-
⑯	Shift Weight Fastener	<b>20 in-lb (2 Nm)</b>
⑰	Clutch Button	-

---

REF	DESCRIPTION	TORQUE
⑱	Washer	-
⑲	Spider Pin	-
⑳	Bushing	-
㉑	Roller	-

## CLUTCH DISASSEMBLY

**CAUTION**

The clutch assembly is a precisely balanced unit. Never replace parts with used parts from another clutch assembly!

1. Using a permanent marker, mark the cover, spider, and moveable sheave for reference, as the cast in X's may not have been in alignment before disassembly.

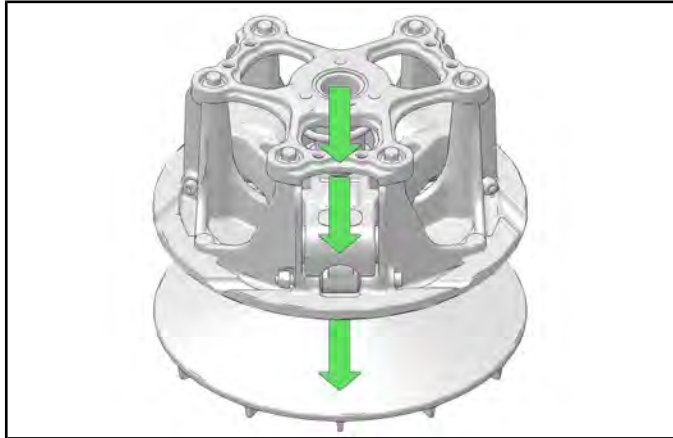

2. Remove cover bolts ① evenly in a cross pattern and remove cover plate ②.

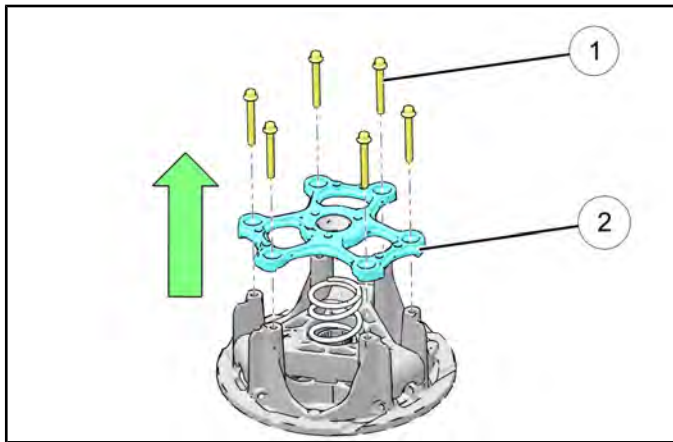

3. Inspect area on shaft where bushing rides for wear, galling, nicks, or scratches. Replace clutch assembly if worn or damaged.

4. Remove and inspect the clutch spring ④. Refer to **Drive Clutch Spring Inspection page 6.14** procedure.

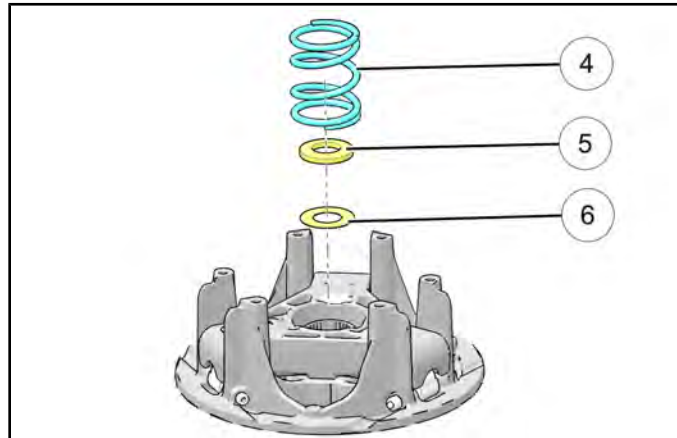

5. Remove and inspect Belleville washer ⑤ and washer ⑥. Replace if necessary.

**IMPORTANT**

Belleville washer must be installed with dome facing the outer post.

## BEARING INSPECTION

- Verify there is no binding or rough spots. If problems are noted continue with disassembly.

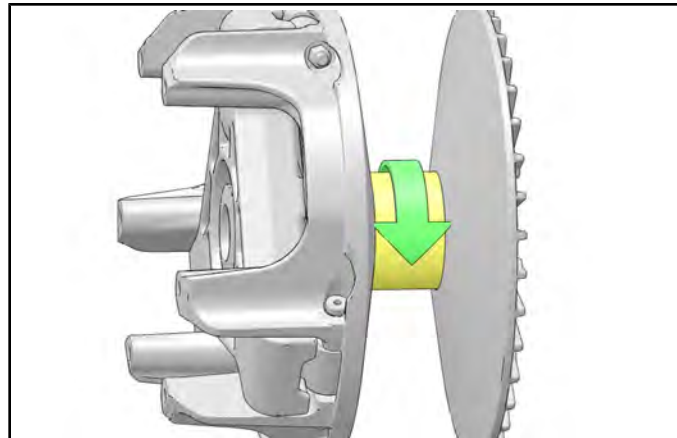

## BUTTON TO TOWER CLEARANCE INSPECTION

1. Inspect for any clearance between spider button to tower. If clearance exceeds specification, replace all buttons and inspect surface of towers. Refer to **Spider Removal page 6.11** procedure.

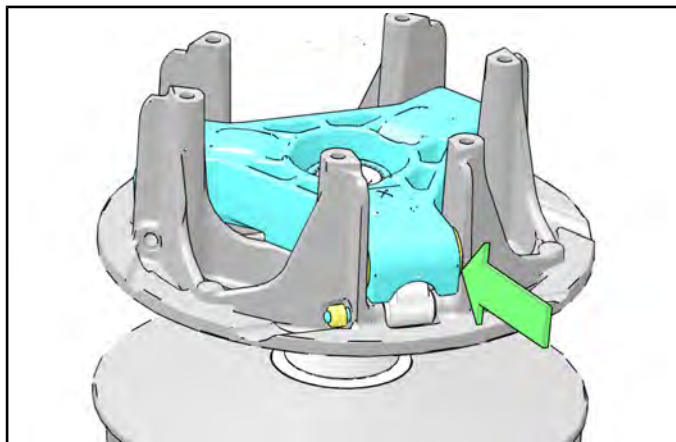

Button to Tower Clearance:  
0.000 - 0.020"

2. Inspect sheave surfaces. Replace the entire clutch if worn, damaged or cracked.

## SPIDER REMOVAL

1. Remove the spider assembly. If the spider cannot be removed by hand, use a conventional 3-jaw puller as shown to remove the spider from the clutch assembly.

### IMPORTANT

Do not pull on the outer fingers of the spider or damage may occur. Position 3 jaw puller in the positions shown ⑦.

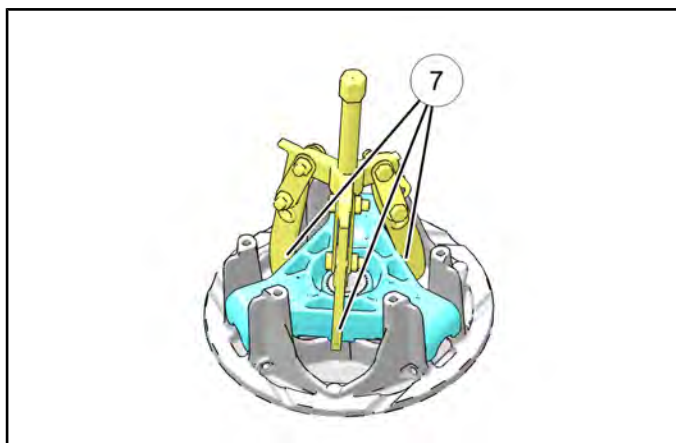

## ROLLER, PIN, AND THRUST WASHER INSPECTION

1. Inspect all rollers ③, roller pins ④, roller washers ②, and roller caps ① by pulling a flat metal rod across the roller.
2. Turn roller with your finger. If you notice resistance, galling, or flat spots, replace all the rollers.

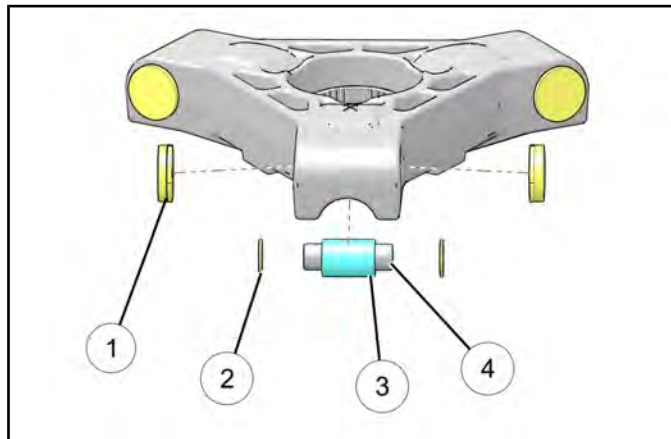

## ROLLER REPLACEMENT

### IMPORTANT

When replacing rollers, install new roller pins and thrust washers.

1. Remove the roller buttons. Inspect and replace if excessively worn.
2. Press the roller pin out using a correctly sized punch and commercial press to remove the roller.

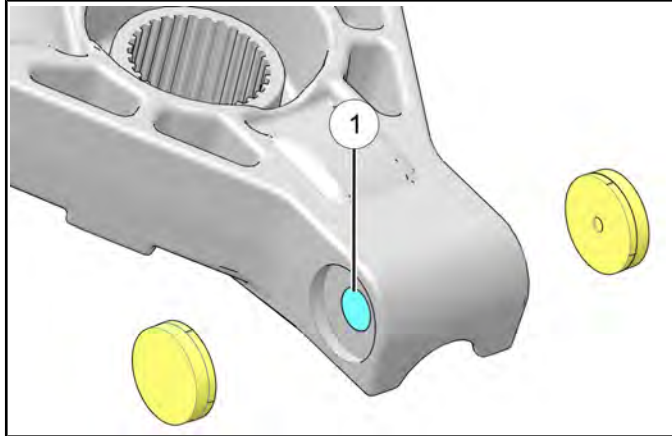

3. Install the new roller and thrust washers ② and press in a new roller pin using a commercial press and correctly sized punch.

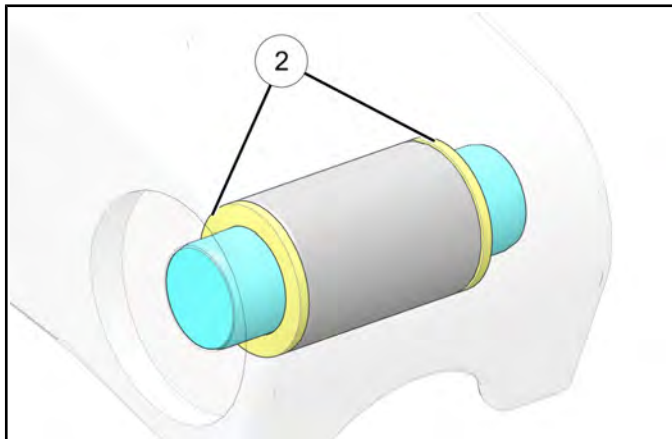

4. Install the roller buttons and verify smooth operation of the roller.

## SHIFT WEIGHT INSPECTION

- Remove shift weight fasteners ① and weights ②. Inspect the contact surface of the weight ②. The surface should be smooth and free of dents or gall marks. Inspect the weight pivot bore ③ and bolts for wear or galling. Also inspect the shift weight bushing for wear. Replace if necessary. If weights or bolts are worn or broken, replace in sets of three with new bolts and nuts.

### CAUTION

The clutch assembly is a precisely balanced unit. Never replace parts with used parts from another clutch assembly.

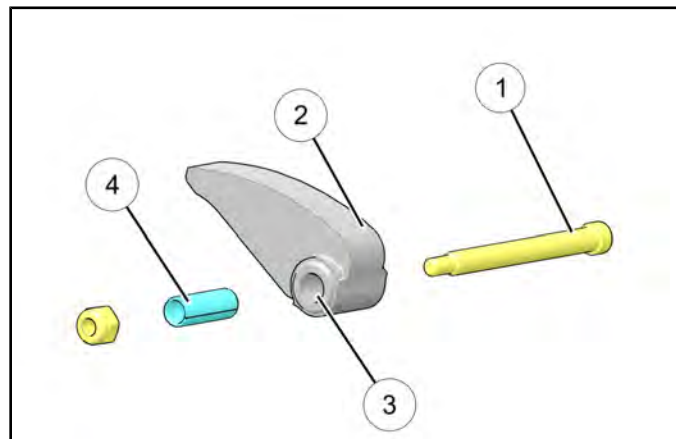

### NOTICE

A damaged shift weight is usually caused by a damaged or stuck roller in the spider assembly. Refer to **Roller, Pin, and Thrust Washer Inspection page 6.11** procedure.

## CLUTCH INSPECTION

### NOTICE

Remove cover, spring and spider following instructions for drive clutch disassembly, then proceed as follows:

1. Remove the clutch spacer ①, washers ② and ④, and needle bearing ③ from the Sheave assembly ⑤.

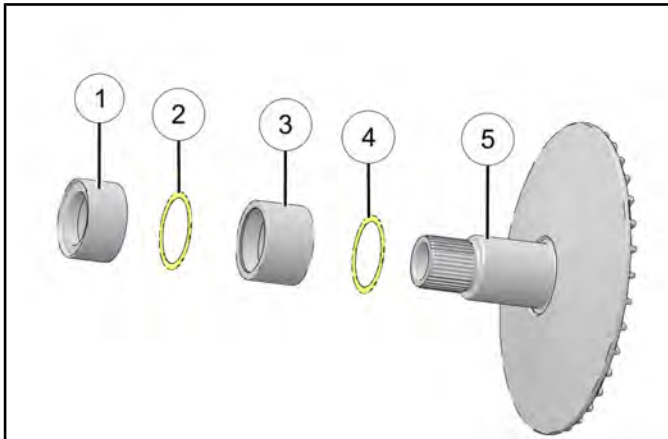

2. Verify there are no binding or rough spots on the bearing. If problems are noted, replace bearing ⑦ and washers ⑥. Refer to Bushing Service page 6.15.

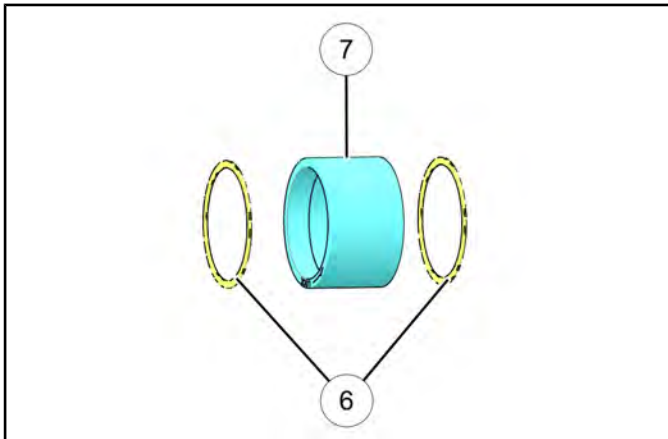

3. Inspect the moveable clutch sheave ⑧ for damage or wear.

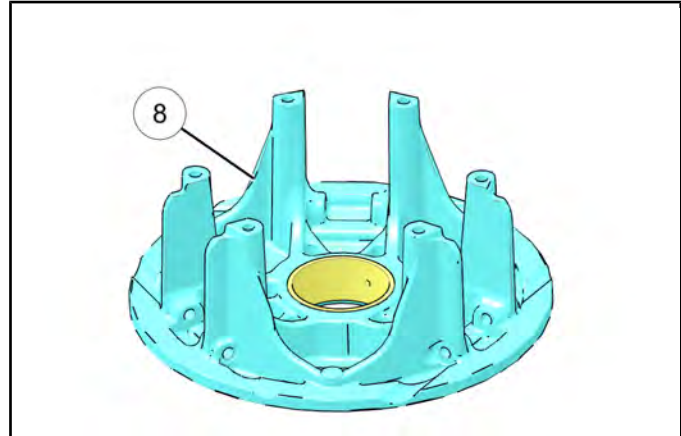

4. Inspect surface of shaft for pitting, grooves or damage. Measure the outside diameter and compare to specifications. Replace the drive clutch assembly if shaft is worn or damaged.

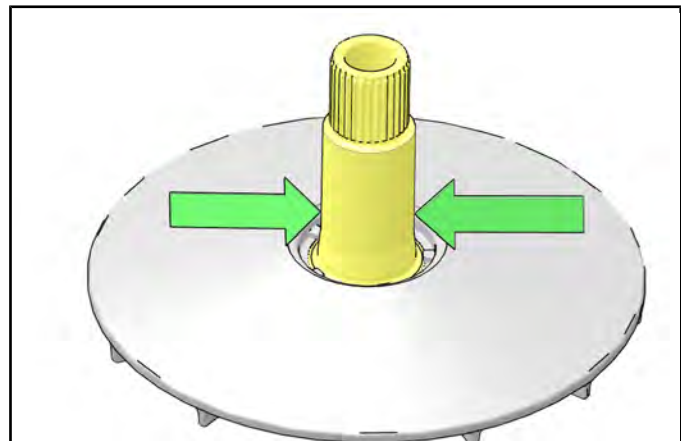

### MEASUREMENT

Shaft Diameter: **1.416" (35.975 mm)**  
Service Limit: **1.413" (35.913 mm)**

5. Visually inspect Vespel® thrust washers for damage. Measure the thickness and compare to specification. Replace if worn or damaged.

### MEASUREMENT

Thrust Washer Thickness:  
Standard: **0.030 – 0.040" (0.76 - 0.96 mm)**  
Service Limit: **0.020" (0.50 mm)**

6

### DRIVE CLUTCH SPRING INSPECTION

- Measure the Drive Clutch Spring height. Compare to specification and replace if necessary.

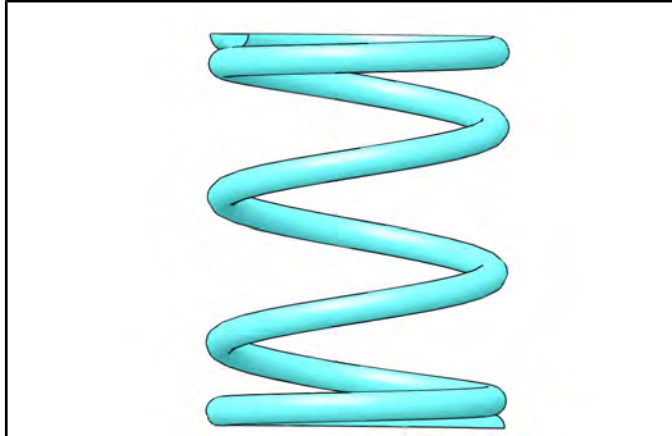

#### MEASUREMENT

Drive Clutch Spring Height:  
7044938: 3.76 in (95.43 mm) 7045110: 4.60"  
(116.74mm) 7045326: 3.83" (97.26mm)

### DRIVE CLUTCH BUSHINGS INSPECTION

1. Inspect the Teflon® coating on the Moveable Sheave bushing, Drive Clutch Cover Bushing, and the One-way Bearing Bushing. Inspect for signs of wear, grooving or cracking. De-glaze sheave surfaces with a 3M Scotch-Brite™ Pad if needed.

#### NOTICE

Replace the bushing(s) if more brass than Teflon® is visible on the bushing(s). Refer to **Bushing Service page 6.15** procedure.

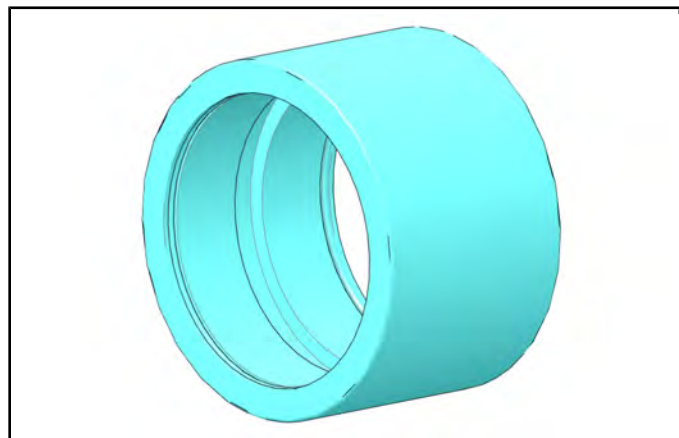
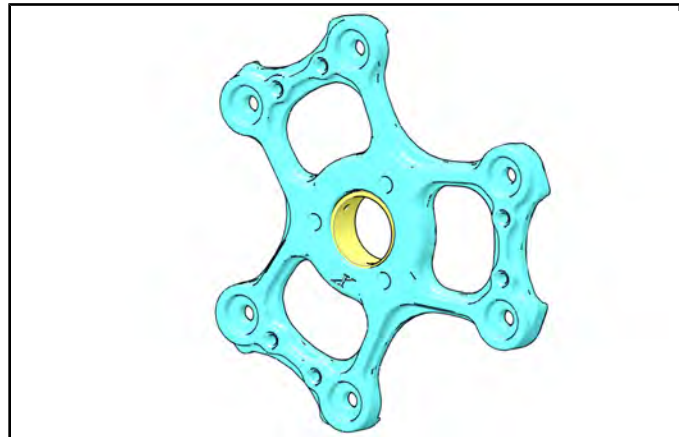
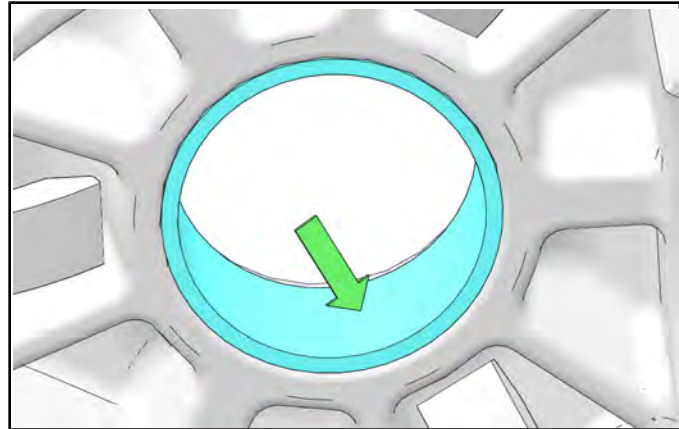

## BUSHING SERVICE

### MOVEABLE SHEAVE - BUSHING REMOVAL

1. Remove clutch as outlined previously in this chapter.
2. Install handle end of the Piston Pin Puller (PN2870386 ) ① securely into bench vise and lightly grease puller threads.

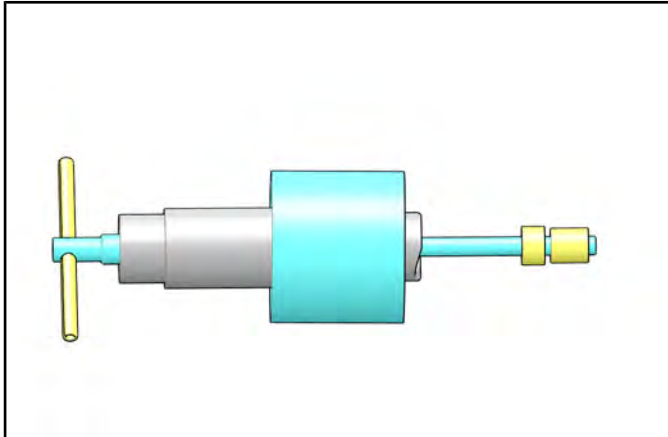

3. Remove nut from puller rod and set aside.
4. Install adapter cup (PN 5020632) ② onto puller.

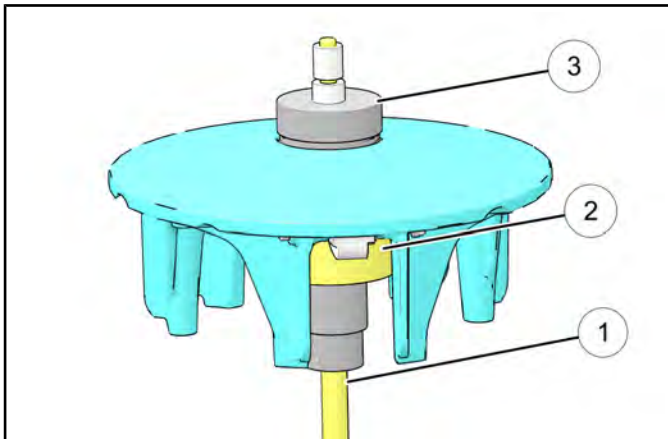

5. With towers pointing toward the vise, slide sheave onto puller rod.
6. Install puller tool (PN 5020629) ③ into center of sheave with "A side" toward sheave.
7. Install nut onto end of puller rod and hand tighten. Turn puller barrel to increase tension on sheave if needed. Using a hand held propane torch, apply heat around outside of bushing until tiny smoke tailings appear.
8. Turn sheave counterclockwise on puller rod until it comes free. Lift sheave off puller.
9. Remove nut from puller rod and set aside.
10. Pull bushing removal tool and adapter from puller rod. Remove bushing from tool and discard.

### DRIVE CLUTCH BUSHING INSTALLATION

1. Place adapter cup (PN 5020632) ② on puller.

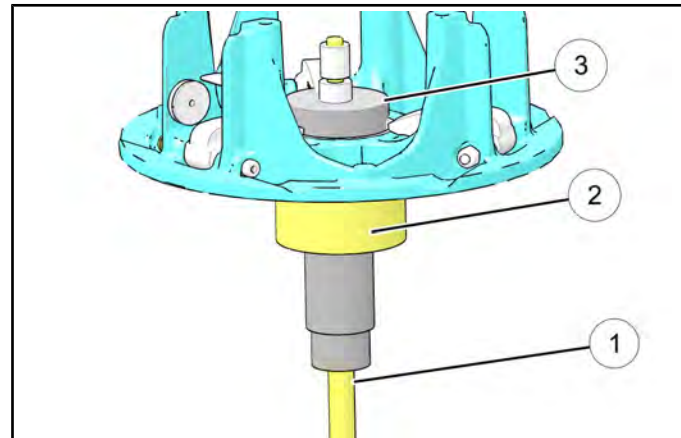

2. Apply Loctite® 620 evenly to bushing bore inside moveable sheave.
3. Set bushing in place on sheave.
4. Insert installation puller tool (PN 5020634) ③ with "A" side down, into center of bushing.
5. With towers pointing upward, slide sheave, bushing and tool onto puller rod.
6. Install nut on puller rod and hand tighten. Turn barrel to apply additional tension if needed.
7. Turn sheave counterclockwise, making sure bushing is drawn straight into bore. Continue until bushing is seated.
8. Remove nut from puller rod and set aside.
9. Remove sheave from puller.
10. Remove installation tool.

### COVER BUSHING REMOVAL

1. Install adapter cup (PN 5020632) ② on puller.

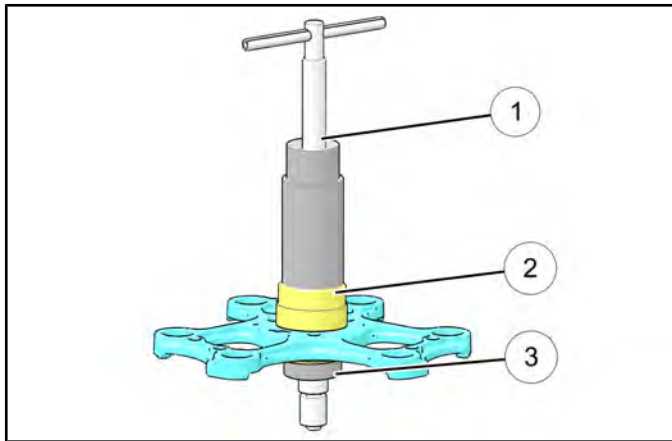

#### IMPORTANT

When removing the bushing, the outside of the cover should be facing the barrel of the Piston Pin Puller as shown or damage to the cover may result.

2. From inside of clutch cover, insert adapter tool (PN 5020629) ③ into cover bushing.
3. With outside of cover toward the puller barrel, slide cover onto puller.
4. Install nut onto puller rod and hand tighten. Turn puller barrel to increase tension as needed.
5. Turn clutch cover counterclockwise on puller rod until bushing is removed and cover comes free.
6. Remove nut from puller rod and set aside.
7. Remove bushing and bushing removal tool from puller. Discard bushing.

### COVER BUSHING INSTALLATION

1. Apply Loctite® 620 evenly to bushing bore in cover.
2. Install adapter cup (PN 5020632) on puller, insert cover onto puller rod, placing inside of cover toward vise.

#### IMPORTANT

When installing the bushing, the inside of the cover should be facing the barrel of the Piston Pin Puller or damage to the cover may result.

3. Working from outside of cover, insert new bushing and adapter tool (PN 5020634) into center of clutch cover.
4. Install nut on rod and hand tighten. Turn puller barrel to apply more tension if needed.

5. Turn clutch cover counterclockwise on puller rod until bushing is seated.
6. Remove nut from puller rod. Take installation tool and clutch cover off rod.

## CLUTCH ASSEMBLY

**NOTICE**

The Teflon® bushings are self-lubricating.

**CAUTION**

**Do not apply oil or grease to the bushings.**

Reassemble the drive clutch in the following sequence. Be sure the "X", or the marks that were made earlier are aligned during each phase of assembly.

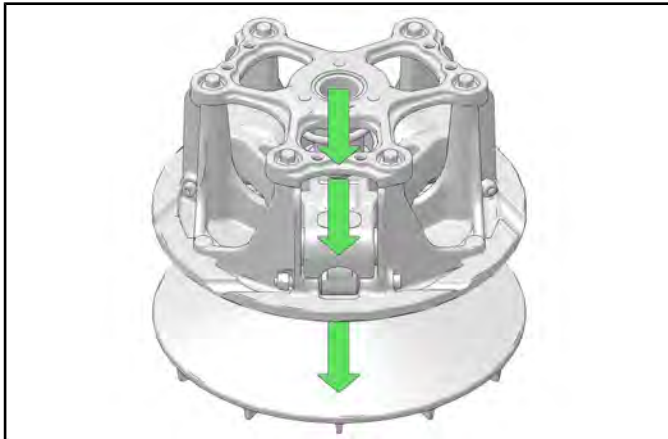

1. Install two washers ①, needle bearing ②, and clutch spacer ③ onto the stationary sheave in the order shown.

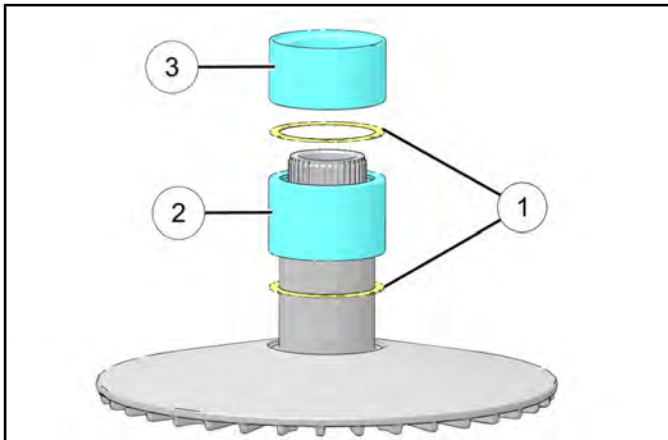

2. Install clutch spider as shown ④.

**NOTICE**

If necessary, once the splines are aligned properly, an arbor press may be used to properly seat the clutch spider.

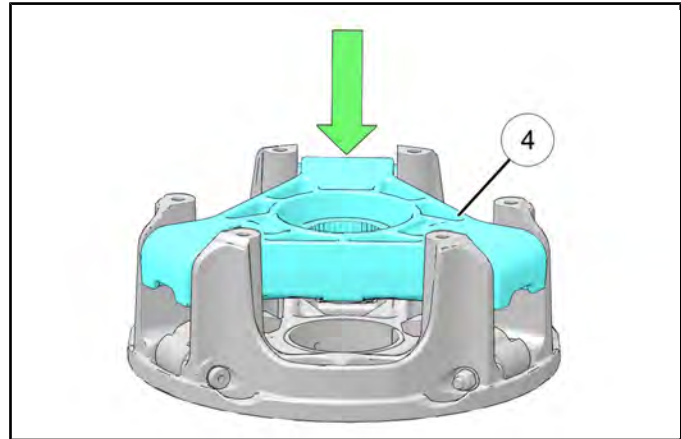

3. Install washer ⑤, belleville washer ⑥, and clutch spring ⑦.

**IMPORTANT**

Belleville washer must be installed with dome facing the outer post.

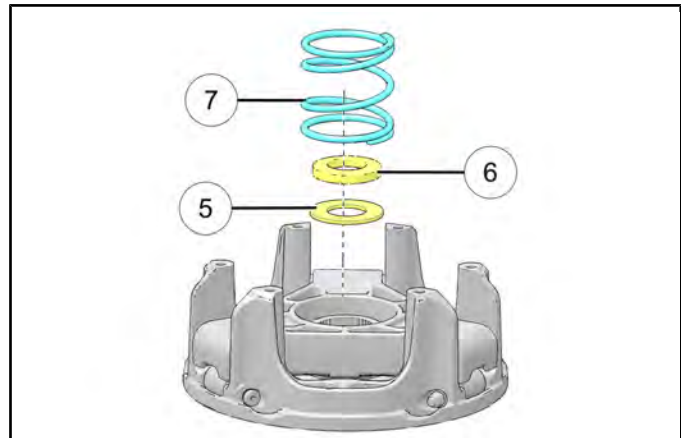

6

4. Install the clutch cover ⑧ and clutch cover bolts ⑨. Hand tighten bolts.

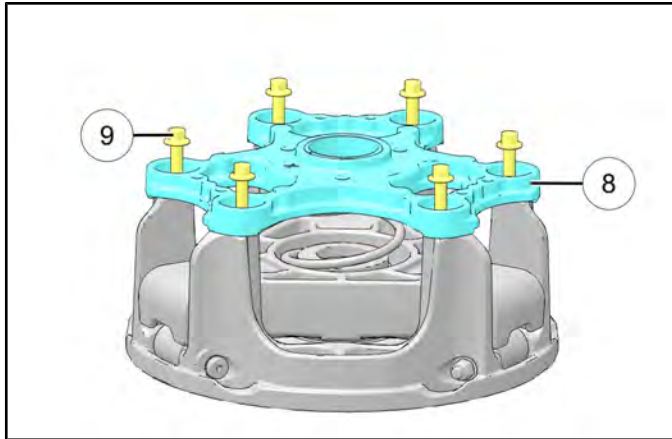

5. Torque cover bolts in a cross pattern evenly to specification.

**TORQUE**

Drive Clutch Cover Bolts:  
**15 ft-lbs (21 Nm)**

6. Install drive clutch assembly and drive clutch bolt ⑩. Torque bolt to specification.

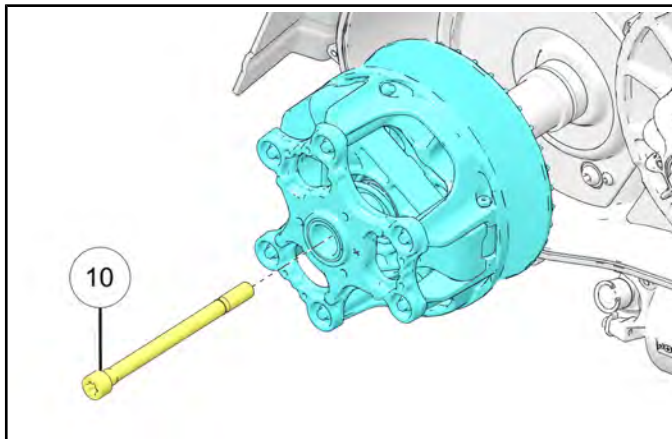

**TORQUE**

Drive Clutch Bolt:  
**140 ft-lbs (190 Nm)**

## DRIVE CLUTCH INSTALLATION

1. Install drive clutch stationary sheave.
2. Install drive clutch moveable sheave and drive clutch retaining bolt ⑦. Torque fastener to specification.

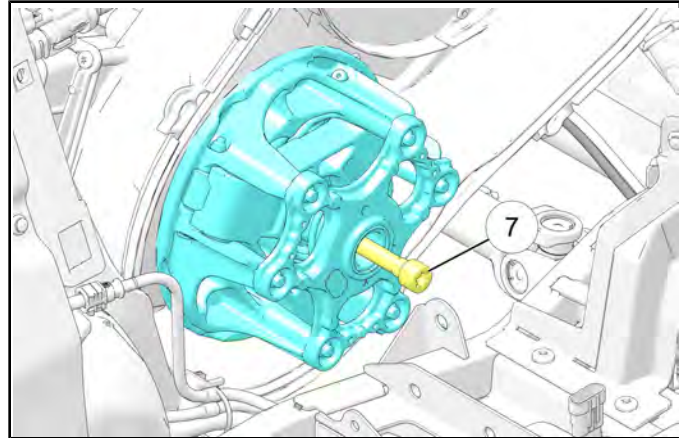

**TORQUE**

Drive Clutch Retaining Bolt:  
**Step 1: 140 ft-lbs (190 Nm)**  
**Step 2: Loosen two full turns (720°)**  
**Step 3: 118 ft-lbs (160 Nm)**

3. Install the drive belt.
4. Install outer clutch cover. Install five fasteners ③ and engage 1/4 turn latches to secure the cover. Torque fasteners to specification.

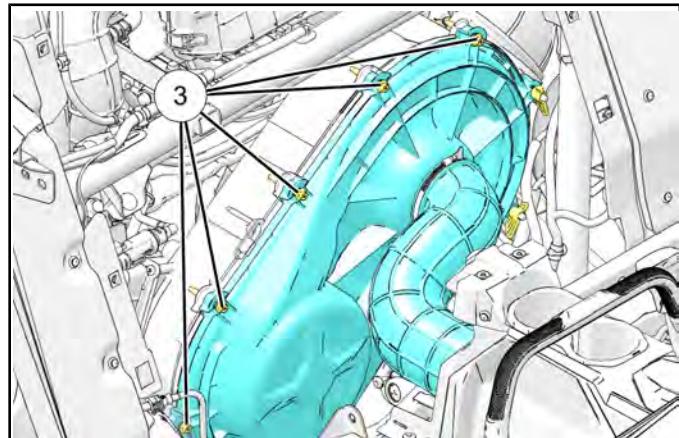

**TORQUE**

Outer PVT Cover Fasteners:  
**60 in-lbs (7 Nm)**

5. Install clutch intake hose. Tighten hose clamp ②.  
Torque hose clamp to specification.

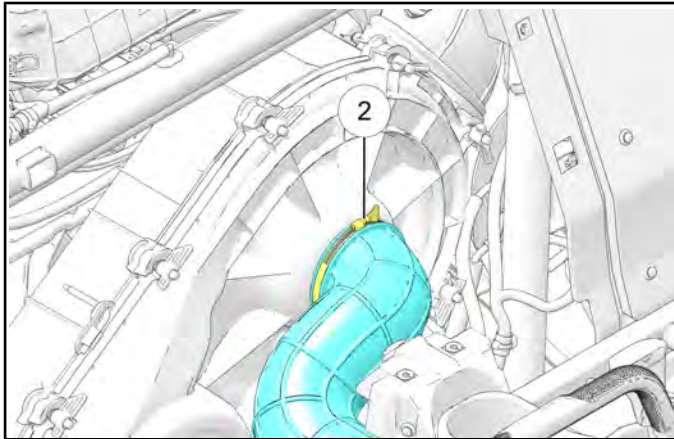
**TORQUE**

PVT Intake Hose Clamp:  
**35 in-lbs (4 Nm)**

6. Install upper and lower rear close-off panels.
7. Install seats. On 4-seat models, install the rear seats.

## DRIVEN CLUTCH SERVICE

### DRIVEN CLUTCH REMOVAL

1. Park vehicle on a level surface.
2. Remove seats. On 4-seat models, remove the rear seats.
3. Remove upper and lower rear close-off panels.
4. Loosen hose clamp ② and remove the PVT intake hose.

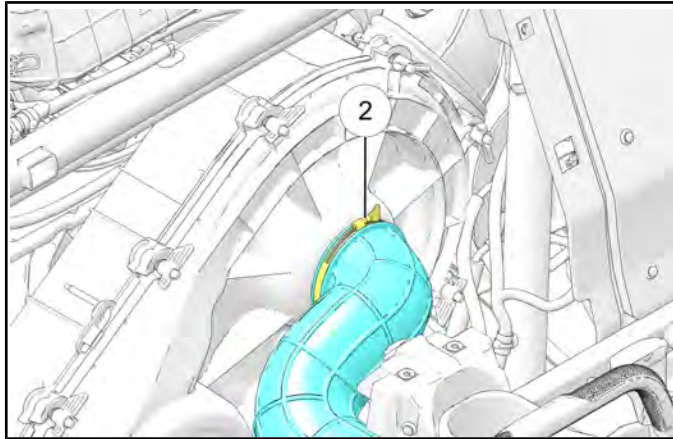

5. Remove five fasteners ③, disengage remaining 1/4 turn latches, and remove the outer PVT cover.

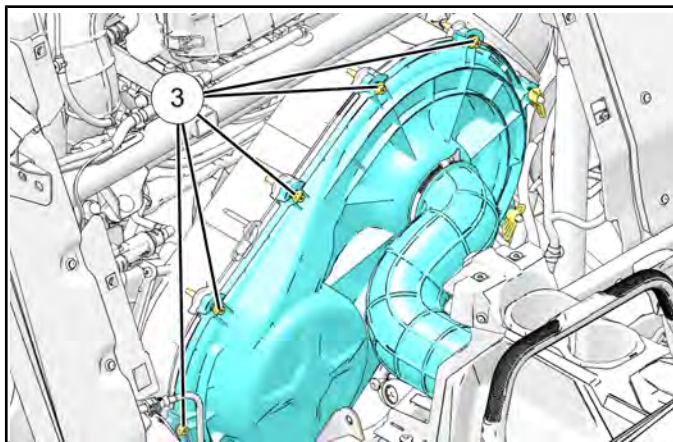

6. Remove the drive belt.

7. Remove bolt ④, spacer ⑤, and washer ⑥. Remove the driven clutch.

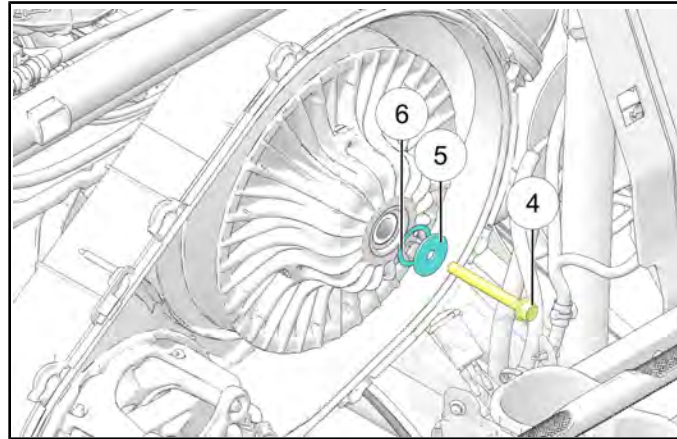

**DRIVEN CLUTCH ASSEMBLY VIEW**

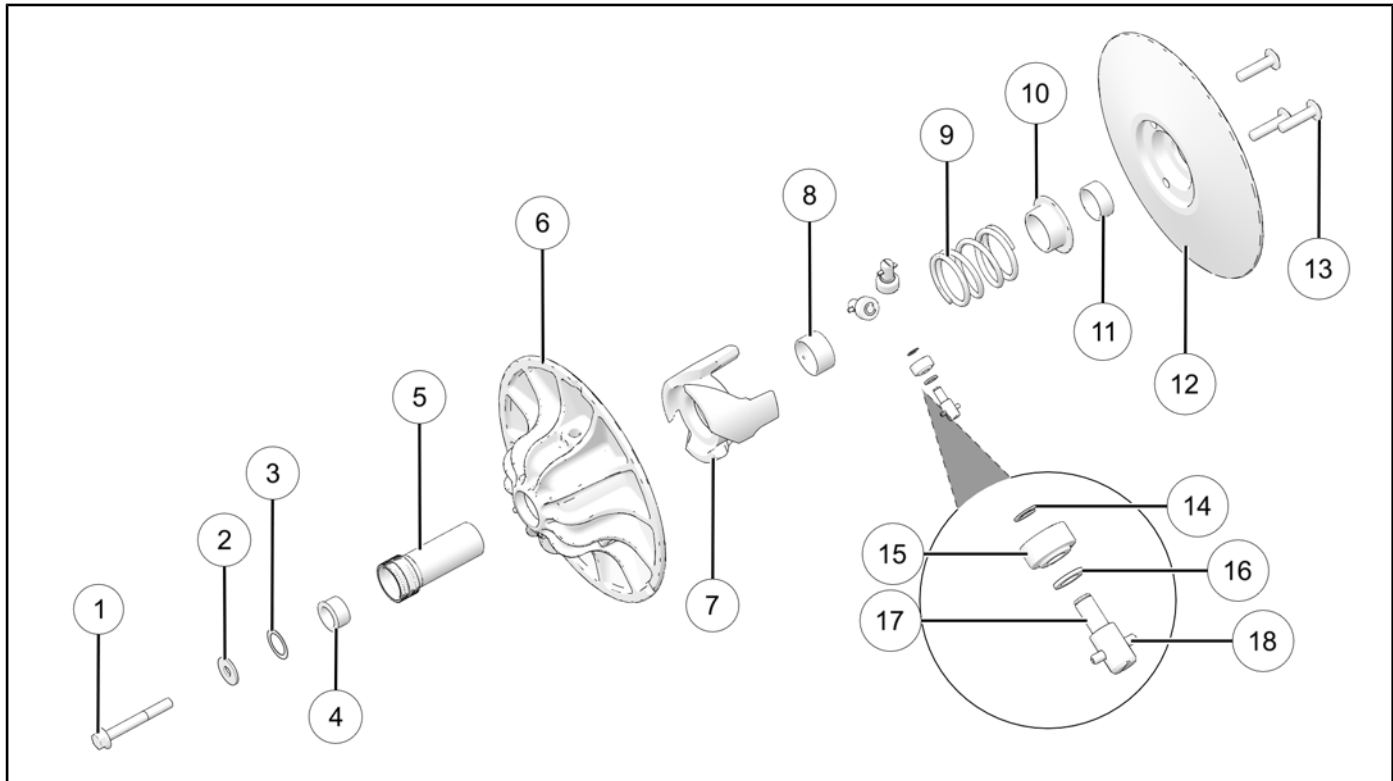

**6**

① Driven Clutch Bolt <b>2020 Models: 43 ft-lbs (58 Nm)</b>	⑩ Spring Cup
② Washer	⑪ Bushing
③ Shim	⑫ Moveable Sheave
④ Bushing	⑬ Helix Fasteners <b>32 ft-lbs (44 Nm)</b>
⑤ Driven Post	⑭ E-Clip
⑥ Stationary Sheave	⑮ Roller
⑦ Helix	⑯ Washer
⑧ Bushing	⑰ Roller Pin
⑨ Spring	⑱ Spring Pin

## DRIVEN CLUTCH DISASSEMBLY

1. Remove driven clutch from the transmission input shaft.

### IMPORTANT

It is important to mark the position of the helix cover, sheaves and spider with a tape or grease marker before disassembly. Some components will have X's on the components for alignment reference. This helps with clutch assembly and maintains clutch balance.

2. Separate the sheaves and place the driven clutch (helix side up) into the Universal Clutch Compressor.

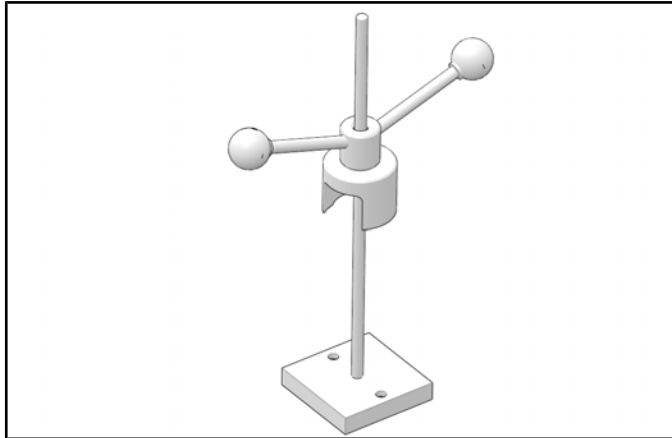

Universal Clutch Compressor: **PU-50518-A**

3. Spin the compressor down until it just starts to contact the helix cover. Remove the three fasteners ① that secure the cam (helix) assembly using a T50 Torx driver. Remove the universal clutch compressor and stationary sheave.

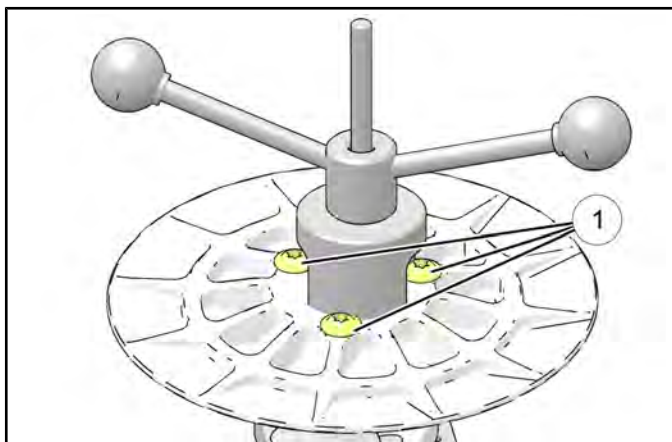

### ⚠ CAUTION

The helix cover is loaded by the spring. Not using a proper compressor may result in personal injury or damage to the clutch.

4. Remove spring cap ② and clutch spring ③ from the helix ④.

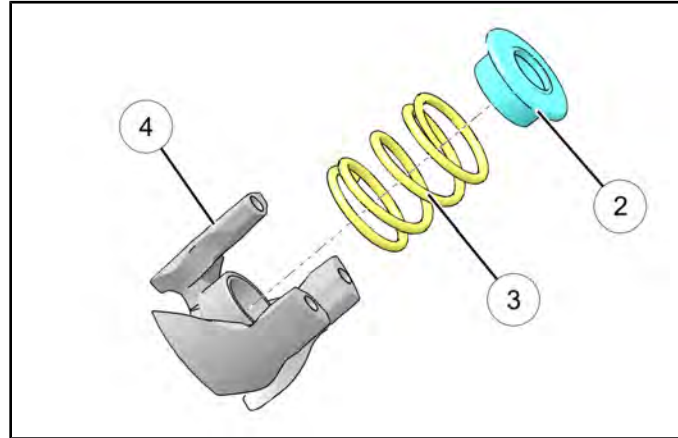

### IMPORTANT

Mark Helix to Sheave hole orientation before removing helix.

5. Inspect roller for play and wear or rough spots by rotating it. If excessive wear, rough spots, or play exists, remove the E-clip ⑤, Roller ⑥, and Washer ⑦ from sheave. Replace as necessary.

### NOTICE

Roller pin is not serviceable.

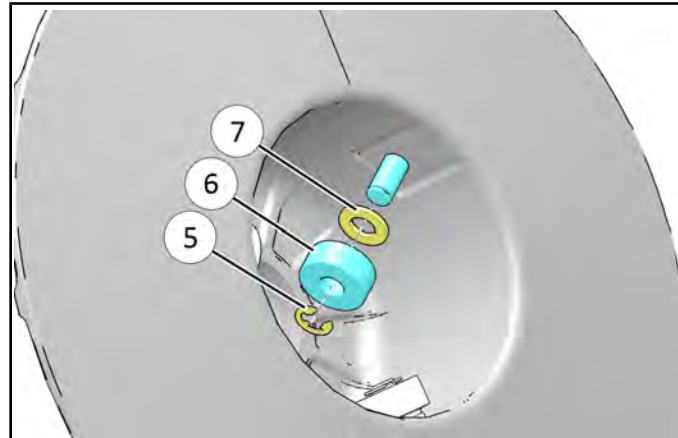

6. Inspect the sheaves for excessive wear or damage. Replace if necessary.

## HELIX AND MOVABLE SHEAVE BUSHING INSPECTION

1. Inspect the Teflon® coating ① on the moveable sheave bushing. Inspect Sheave for signs of wear, grooving or cracking. De-glaze sheave surfaces with a 3M Scotch-Brite™ Pad if needed. Replace if needed.

Moveable Sheave Bushing Inspection:  
Replace the movable sheave if more brass than Teflon® is visible on the bushing.

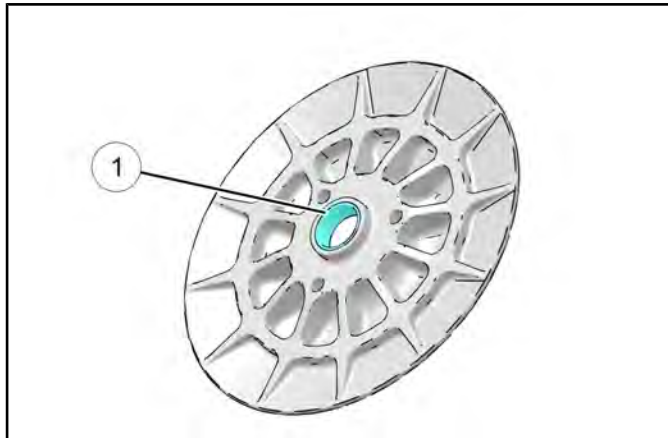

2. Inspect the Teflon® coating ② on the Helix bushing. Inspect Helix for signs of wear, grooving or notching on ramps. De-glaze surfaces with a 3M Scotch-Brite™ Pad if needed. Replace if needed.

Helix Bushing Inspection:  
Replace the Helix bushing if more brass than Teflon® is visible on the bushing. Refer to Bushing Service page 6.23 procedure.



## BUSHING SERVICE

### HELIX BUSHING REMOVAL

1. Install the main adapter ① on puller.

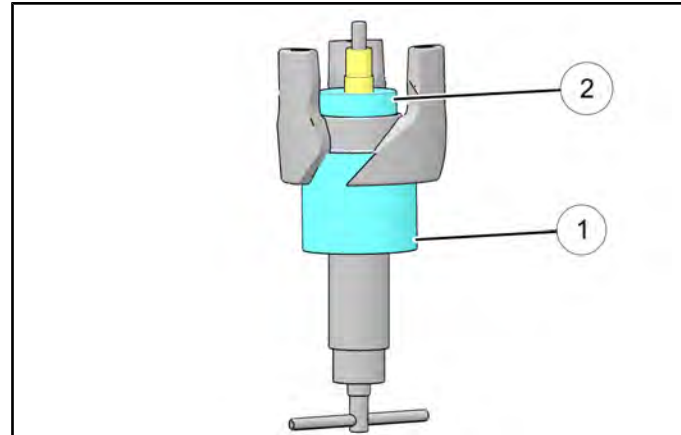

2. From the inside of the Helix, insert bushing adapter ② (PN 5020636) into the bushing. Install spacer and top nut to secure adapter on Helix.
3. Insert the piston pin puller in a vise.
4. Using a pry bar located between the fingers of the helix, turn the helix counter clockwise to remove the bushing.
5. Remove the nut from the puller rod and set aside.
6. Remove the bushing and bushing removal tool from the puller. Discard the bushing.

### HELIX BUSHING INSTALLATION

1. Apply Loctite 620® evenly to bushing bore in cover.

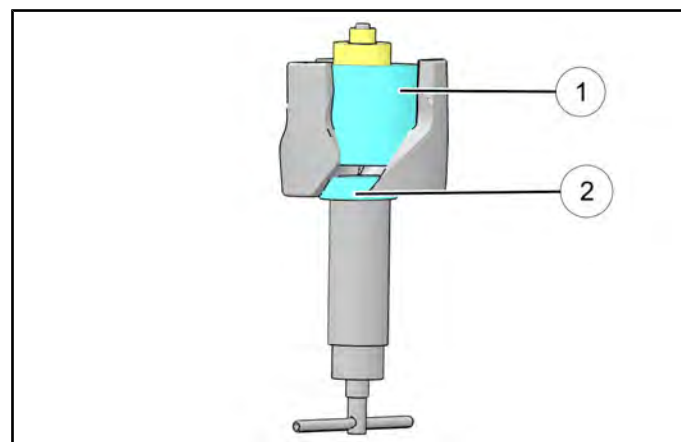

2. From the bottom of the Helix, insert the new bushing and bushing adapter ② (PN 5020636)
3. Install the main adapter ①, spacer adapter, and securing nut on top of the Helix.

## PVT SYSTEM

4. Use a pry bar located between the fingers of the Helix to turn the Helix counterclockwise. Turn until bushing bottoms out.

### IMPORTANT

Only light force is needed to install the bushing. Do not increase pressure after bushing bottoms out, or damage may result to bushing.

5. Remove nut and spacer adapter from puller rod. Remove Helix and bushing adapter from puller rod.

## DRIVEN CLUTCH ASSEMBLY

1. Re-install washer ①, roller ②, and e-clip ③. Ensure e-clip is fully seated and roller rotates freely.

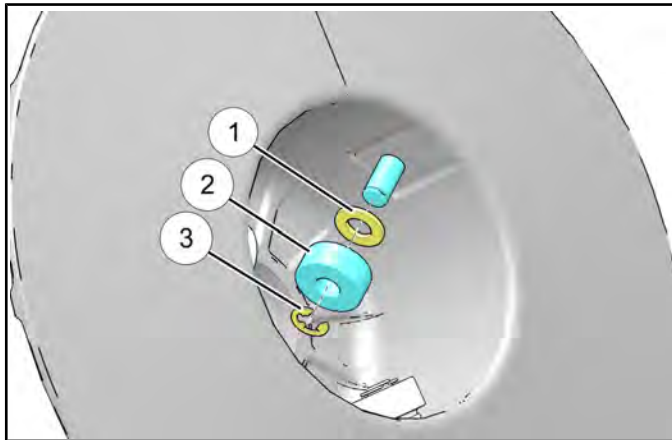

2. Install clutch spring ⑤ and clutch spring cap ⑥ on the helix ④. Ensure the clutch spring is fully seated.

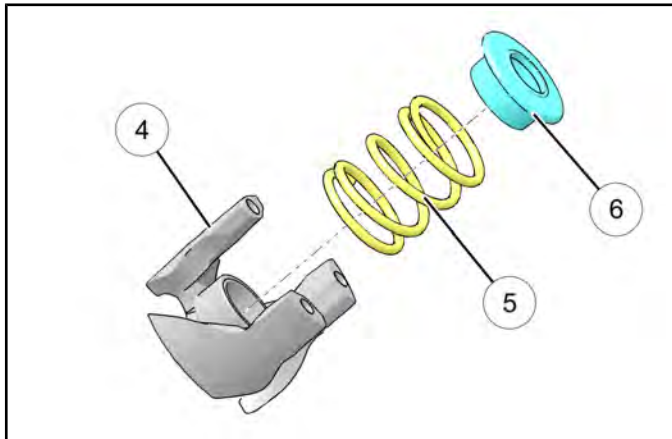

3. Re-install the retaining fasteners ⑦ and movable sheave ⑧ onto the helix ⑨ using previous hole orientation.

### IMPORTANT

Using previous hole orientation will ensure the driven clutch maintains balance.

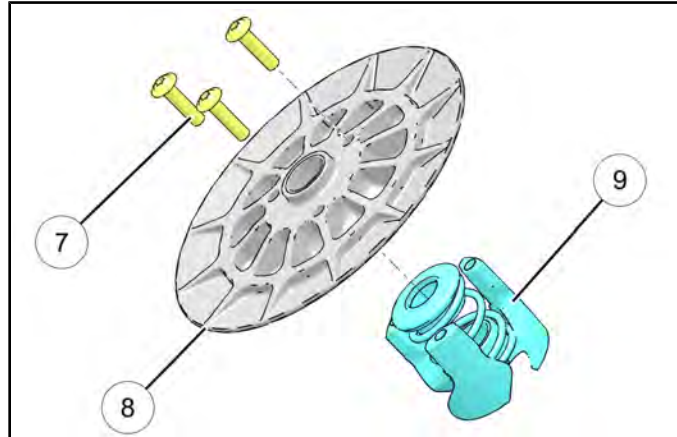

4. Using clutch compressor PU-50518 compress the driven clutch assembly.

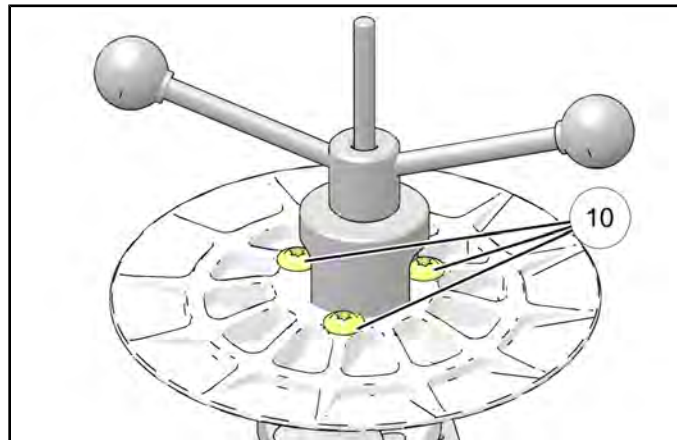

### CAUTION

The helix cover is loaded by the spring. Not using a proper compressor may result in personal injury or damage to the clutch.

5. Torque the three T50 torx fasteners ⑩ to specification.

### TORQUE

Helix Fasteners:  
**32 ft-lbs (44 Nm)**

6. Once back together, verify the alignment marks made during disassembly are properly aligned.

7. Install the stationary and movable sheave on the vehicle. See Driven Clutch Installation.

## DRIVEN CLUTCH INSTALLATION

1. Install driven clutch, bolt ④, spacer ⑤, and washer ⑥. Torque fastener to specification.

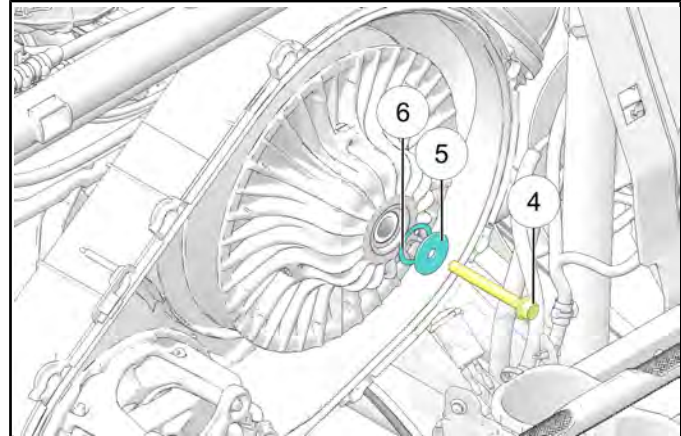

### TORQUE

Driven Clutch Retaining Bolt:  
**55 ft-lbs (75 Nm)**

2. Install the drive belt.
3. Install outer clutch cover. Install five fasteners ③ and engage 1/4 turn latches to secure the cover. Torque fasteners to specification.

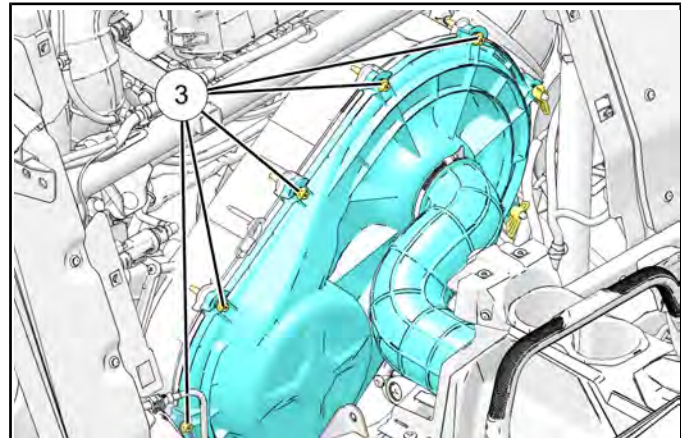

### TORQUE

Outer PVT Cover Fasteners:  
**60 in-lbs (7 Nm)**

6

## PVT SYSTEM

4. Install clutch intake hose. Tighten hose clamp ②. Torque hose clamp to specification.

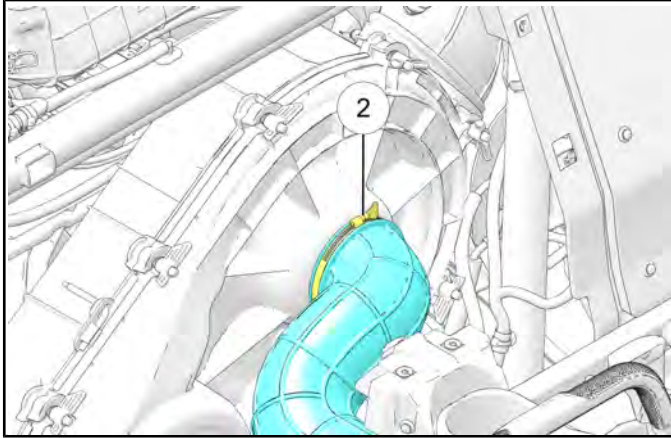

### TORQUE

PVT Intake Hose Clamp:  
**35 in-lbs (4 Nm)**

5. Install upper and lower rear close-off panels.
6. Install seats. On 4-seat models, install the rear seats.

## DRIVEN CLUTCH ALIGNMENT

Most vehicles require four to six alignment washers (PN **7557060**) for proper alignment. As many as eight alignment washers or as few as zero may be used.

### IMPORTANT

The main washer directly under the head of the bolt must always be used.

1. Remove the outer clutch cover from the vehicle.
2. Rotate the driven clutch clockwise several times before inspection.
3. Inspect where the belt is riding on the drive clutch.

### NOTICE

A mobile device can be used to capture a picture of the belt tracking to determine if adjustment is needed.

4. Remove the drive belt.

5. Remove the Driven Clutch Bolt and washer.

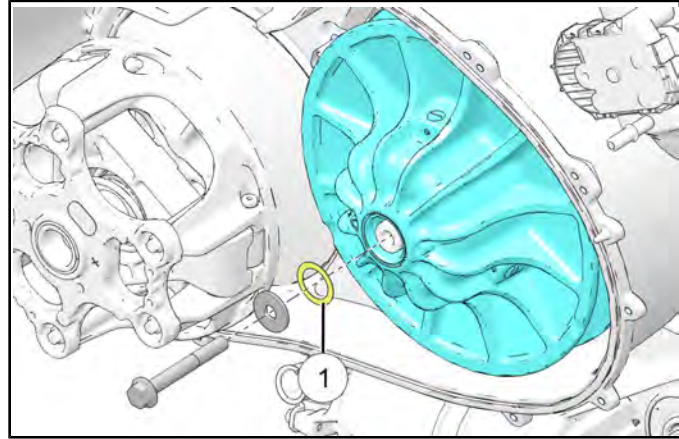

6. Add shims ① to move the belt closer to the inner sheave of the drive clutch, or remove shims to move the belt closer to the outer sheave of the drive clutch.

### IMPORTANT

Ensure the driven clutch splines and transmission splines and shaft are clean and free of debris.

7. Reinstall the washers and Driven Clutch Bolt. Torque to specification.

### TORQUE

Driven Clutch Bolt:  
**2020 Models: 43 ft-lbs (58 Nm)**

### NOTICE

When finished, the driven clutch should not rotate on its own, or should stop with minimal drag when using a new bearing.

8. Remove the drive clutch bolt ② and drive clutch.

**IMPORTANT**

Ensure the drive clutch taper and engine taper are clean and free of debris.

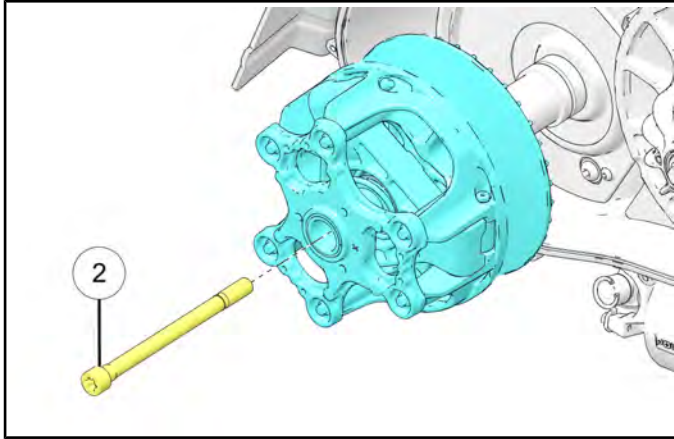

9. Reinstall the drive clutch and bolt. Torque the drive clutch bolt to specification.

**TORQUE**

Drive Clutch Retaining Bolt:  
**140 ft-lbs (190 Nm)**

10. Reinstall the drive belt and outer cover assembly.  
Refer to Belt Installation page .